

# **NOVA**

## **COMPONENT CAR MANUAL**

Whilst every effort has been taken to ensure the drawings and advice given are correct, the company cannot be held responsible for any errors. The information is given in good faith. As the company policy is one of continuous improvement, specifications may alter without notice.

The unauthorised use or copying of any part of this manual is forbidden.

Copyright Nova Sports Cars Ltd.

### **NOVA SPORTS CARS LTD.**

Bridge Garage  
Huddersfield Road  
Mirfield  
W. Yorks WF14 9HS  
Tel. Mirfield (0924) 498811

## BUYING A BEETLE AND PREPARING THE CHASSIS

In the construction of the NOVA one of the most important factors is the chassis. Buying a BEETLE is the first step, so here are a few points to check.

First make sure that the car was manufactured after 1967, as before this date the BEETLE was fitted with the inferior 6 volt electrics, five stud wheels (a real problem) and king pin front suspension.

Another BEETLE to avoid is the 'McPherson front strut' models. These can be identified by a quick inspection inside the front wheel arch which will reveal a large coil spring as opposed to the normal torsion bar system.

Upon finding a BEETLE that complies with the above conditions it is time to begin the work of inspecting the parts in which you are interested.

The best way to avoid problems is to buy a vehicle which can be driven. There are many reasons for this. First (and most important) the transaxle can be checked over. Drive the vehicle normally and listen for whining noises from any of the gears (including reverse). Next accelerate quite hard, release the throttle, then accelerate hard again (this should be done in all gears). If the gear lever suddenly jumps out of gear, then this is a bad box. Any of the above problems are serious enough to warrant gearbox replacement.

Next crawl under the back of the car and check for oil leaks from the pushrod tubes, rocker gaskets, (no problem) and especially from the gearbox bell housing (serious). Check the transmission axle boots (easy to replace, leaks behind the rear brake backplates (no problem). Moving further forward, check the back of the floor pan for corrosion (especially driver side rear as the battery is under the rear seats and acid corrosion is common). Check the floor pans thoroughly and make sure they are in good condition.

## FRONT SUSPENSION

This part must be checked thoroughly as sometimes corrosion can render it useless.

(see fig 1) Prod with screwdriver (HARD)

(A) Check where headstock bolt to chassis

(B) Sharp taps with hammer

(C) Sharp taps with hammer

(D) Where tubes come through shock absorbers mounting turret

(E) Under shock absorber MOUNTING TURRET

(F) Under side of (B) (same treatment).

## REMOVING THE BEETLE BODY

Now that you have got your BEETLE home make sure you have enough room to remove the body. PLEASE DO NOT TEAR IT TO PIECES! keep everything until you are sure that you do not need it.

1. Disconnect and remove the battery.
2. Remove all loose objects (spare wheel etc)
3. Remove good doors/wings/bonnet etc and sell them.
4. Remove fuel tank by removing four clamp bolts (13mm) and store sensibly.
5. Remove two large bolts and keep rubber bushes which hold body to front axle.
6. Disconnect steering column (13mm) from rubber coupling disc (must be renewed). Now sit in the car and check where the steering column wires run through the dash. (DO NOT CUT). Look under the bonnet for the emerging clump of wires and methodically disconnect from various terminals. Now get back inside the car and remove steering column clamp bolts (13mm socket) then remove column from inside the car and store in the garage.
7. Remove seats, glass, and seat belts (exert pressure with feet from inside to remove glass).
8. Remove row of bolts (13mm) from under rear seats.
9. Drain engine oil and air filter first then get some friends round to tip the BEETLE onto its side (make sure it's safe). This will reveal the row of bolts around the floor pan perimeter. Remove the bolts (13mm) and channel washers (keep). Remove the (4 x 19mm) large bolts from front of the pan.
10. Remove and discard rear stabiliser bar (13mm 14mm).
11. Inside the rear wheel arches remove 19mm bolt, just next to shock absorbers top. Now push the BEETLE back onto its wheels. AT LEAST FOUR PEOPLE WILL BE NEEDED FOR THE NEXT STAGE.

Assuming all wires/bolts etc have been removed it should now be possible to lift the body from the chassis. The following is a list of items to keep.

1. Brake master cylinder and reservoir.
2. Fuel tank (fittings only).
3. Headlamp relay.
4. Voltage regulator unit (passenger side under back seat).
5. All channel washers from underside.
6. Rubber floor pan gasket (must be in good condition).
7. Steering column (replace inner).
8. Any bolts, screws, washers, trims etc., as they may be useful later.

FIG. 1

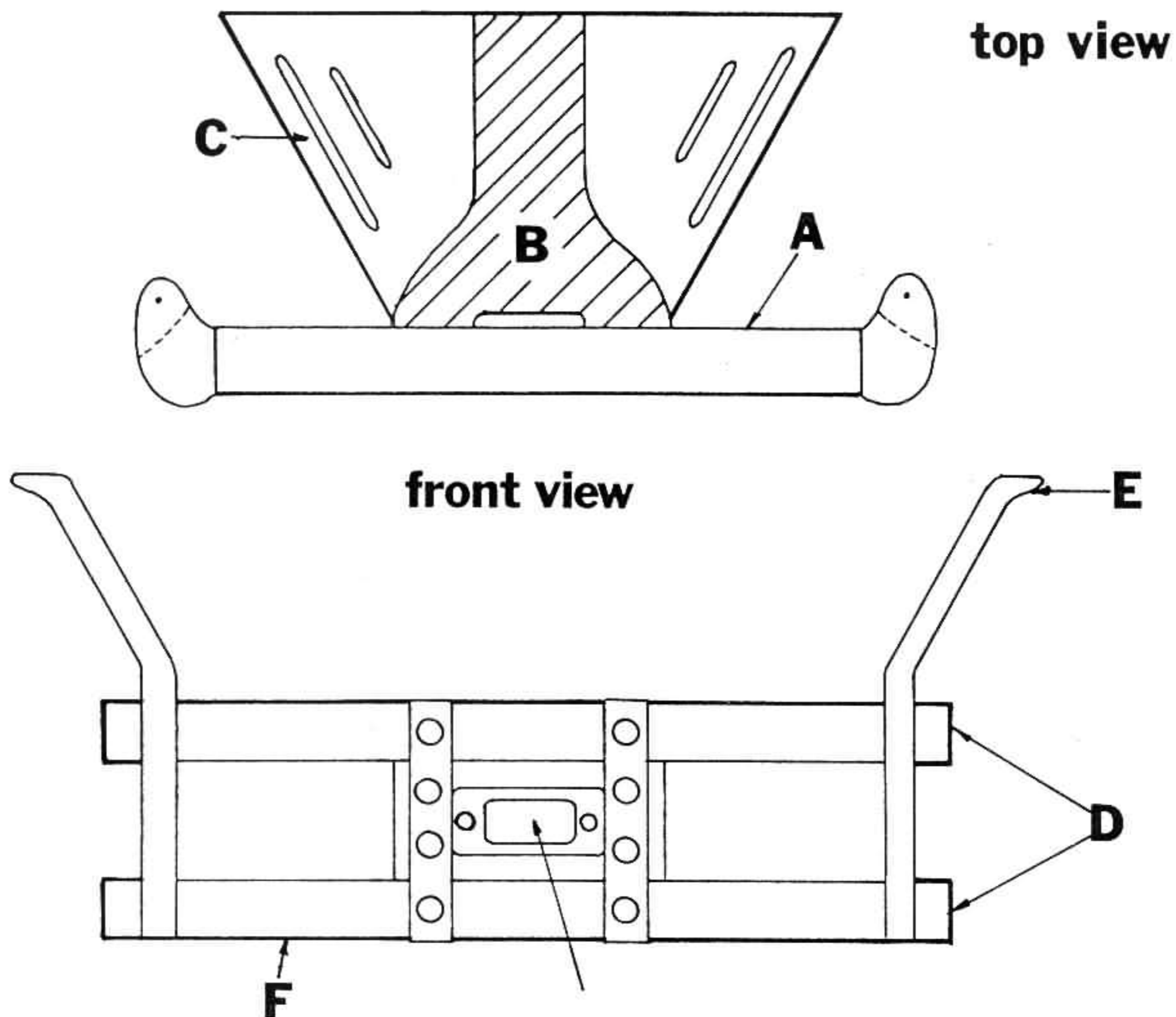

## PREPARING THE CHASSIS

The first step in this section is to make sure that you have kept everything that looks useful.

Put the chassis onto axle stands and remove the engine (4 x 17mm throttle cable heat exchanger cables etc.).

Drain the transaxle oil (17mm allen keys) and discard. Now thoroughly clean the pan with scrapers, wire brushes and rotary brushes (used in a electric drill).This job will take quite some time but is well worth it in the long run.

The replacement of wornparts on the chassis is left to the individual, but it is best to get it over with now as this work is so much easier with the body removed. A thorough inspection of all parts in the brake, steering and suspension must be undertaken by a skilled person for safety reasons. Follow their advice on replacement of parts.

For information on fitting these parts it will be necessary to purchase a workshop manual covering the model concerned (the Haynes manual No.039). These books cover just about every aspect of servicing and repairs and are invaluable during the build up.

Certain modifications can be carried out on the VW chassis to make the car more comfortable to drive.

### 1. THE FLOOR PAN DROP

This modification is desirable for drivers over 5' 8" tall. First it is necessary to mark the floorpan ready for cutting (this is best done with a jig-saw refer to diagram2).Do not cut the heavy gauge tunnel. The pieces that make up the floorpan must be cut and folded as per diagram. If you do not have access to the necessary tools for this job please contact us and we will be glad to make some for you for a reasonable sum (approximately £20.00). Fitting the drop is quite simple although it does involve welding work. The floorpan flap must be lifted above its normal position,the outers in their place. Position inners with their 13mm folded edges (90°) on the tunnel edge formed after cutting the pan.

Now push the previously cut pan into the flanges formed by the side panels and tack weld. Now position the rear panel tack into position and tap flanges over to touch the pan. Fully weld the panels into position and when cool, apply mastic to all joints.

FIG. 2

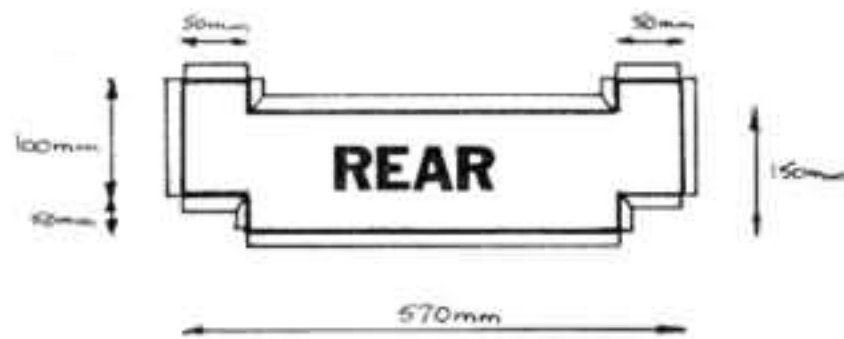
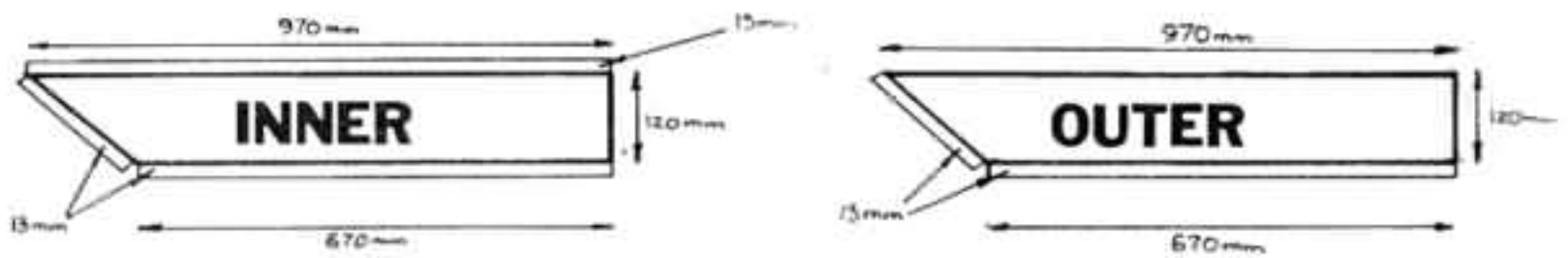
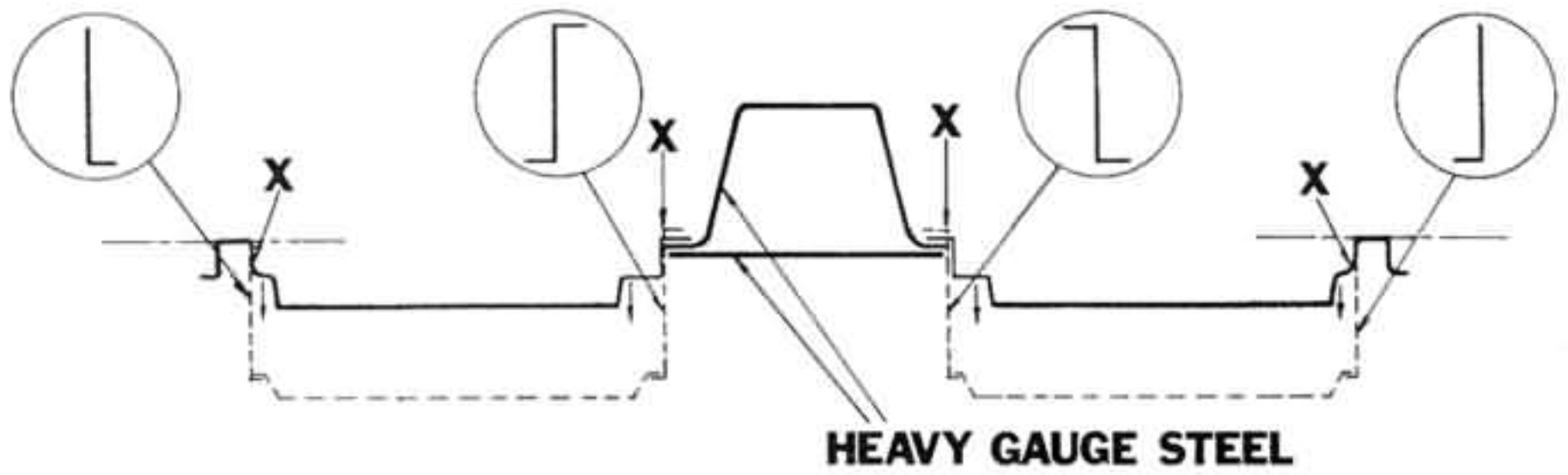
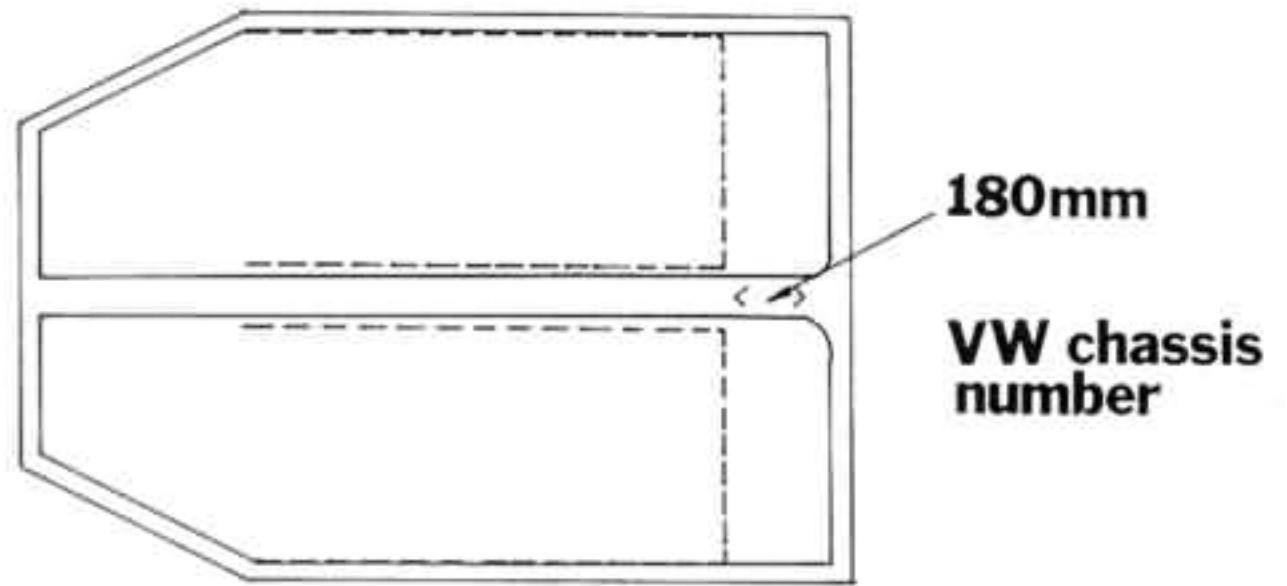

## 2. RE-LOCATE THE GEAR LEVER

The gear lever must be moved back along the tunnel 15-17cm. First remove the handbrake assembly and store.

Second dismantle the gearlever (2 x 13mm) carefully noting the position of the pressed plate (gear section reverse detent).

The gear lever is ball and jointed into a long hollow tube which runs along the tunnel to the gear box.

Just behind the chassis number there is an inspection plate which covers the linkage between the selector tube and the gearbox. Remove and discard this plate. This linkage must be undone from the tube, not from the box (7mm + lock wire) (see Fig. 2).

To remove the selector tube, first refer to diagram on page 2 of the front view. The access plate is clearly visible. This must be removed (2 x 10mm). It is now possible to pass a stiff wire down the tunnel. The end of which is to be shaped as per diagram below.



This wire is hooked over the socket joint and the rod can then be withdrawn. The rod must now be marked for about 28cm along its length as per diagram. This is done so that after cutting the rod it can be welded back together accurately in line. The rod can now be cut (15-17cm). Keep the piece removed and welded back together. Make sure that the weld is filled to bring the tube back to its original diameter. The cutaway diagram of the tunnel shows a carrier which supports the selector tube. The tube itself runs in a nylon bush clipped to the carrier by a wire circlip. These bushes are almost invariably worn and must be replaced. (The VW part number for the bush is 111 701 259a and the retaining ring 111 701 263) DO NOT FIT THE BUSH YET.

Now the tunnel must be cut as diagram (Fig. 11). ALL DISTANCES EITHER SIDE OF LINE X X MUST BE EQUAL.

When both sections are cut, remove them and replace section A into section B original position and tack weld into position every 25mm. Now fit the nylon bush and retaining ring to the selector rod carrier. Now position and weld B back into A's original position and fully weld all joints. Now replace the selector rod and rebuild the linkage. Don't forget to replace the front plate.

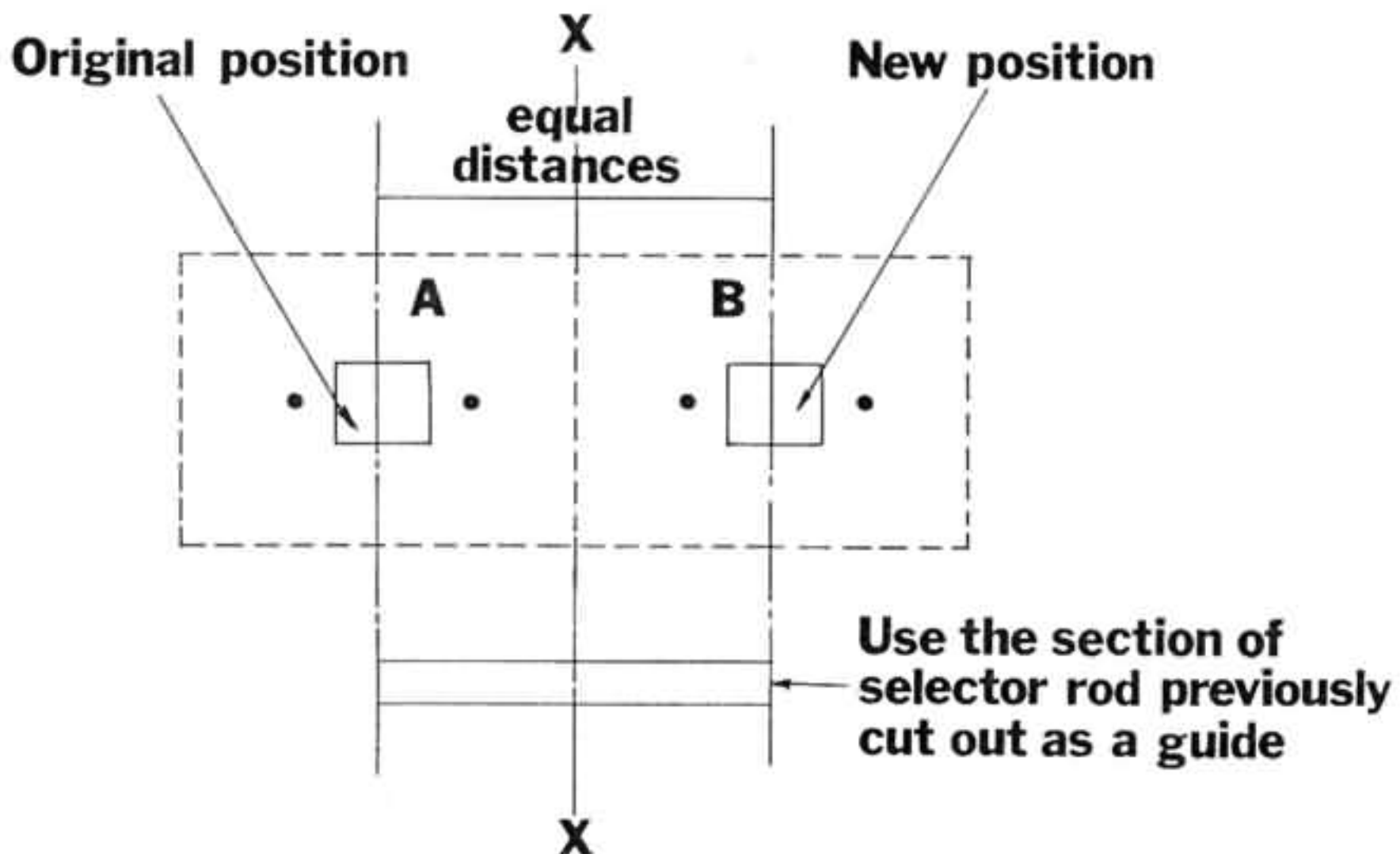
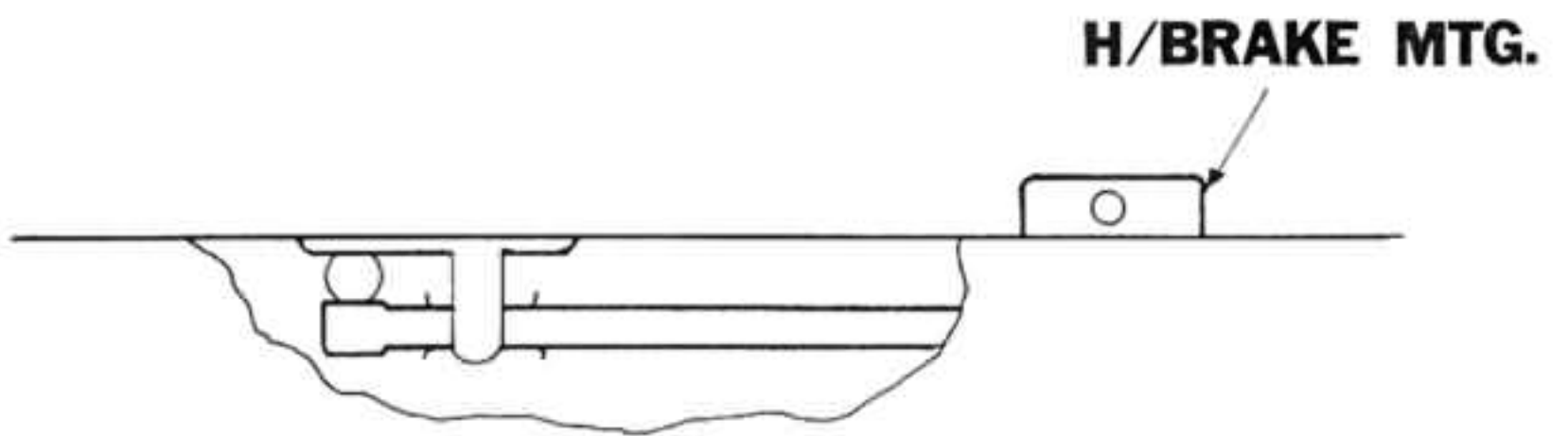
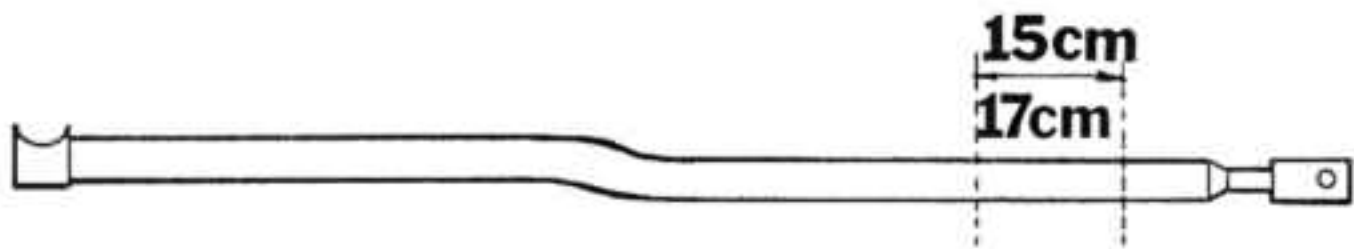
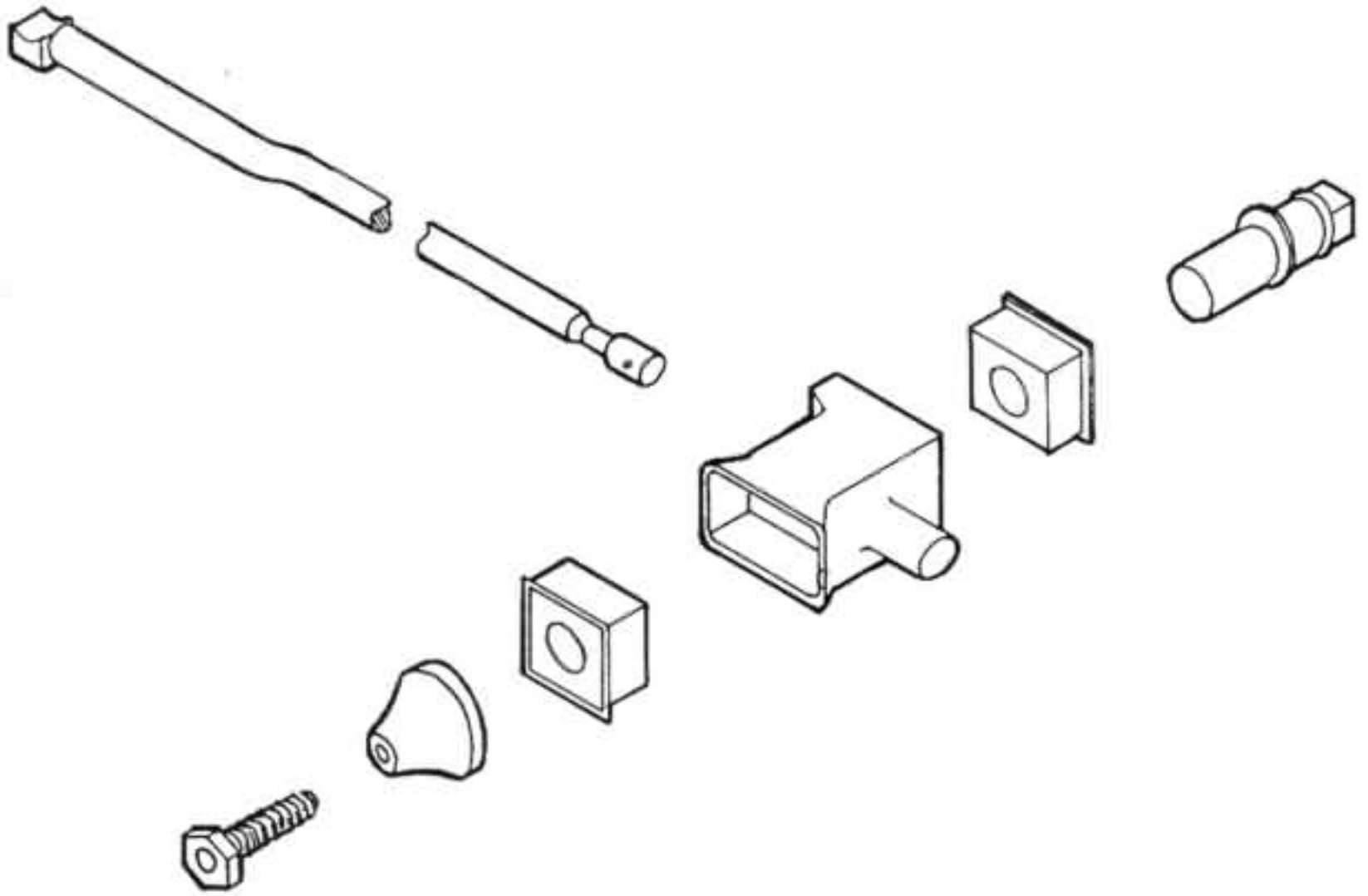

FIG. 3

FIG. 4



## ALTERATIONS TO PEDAL ASSEMBLY

These modifications make the V.W. pedals much easier to use.

### THROTTLE PEDAL

The throttle pedal can be slightly extended by making a new pedal and a spacer (see Fig 5.).

FIG. 5

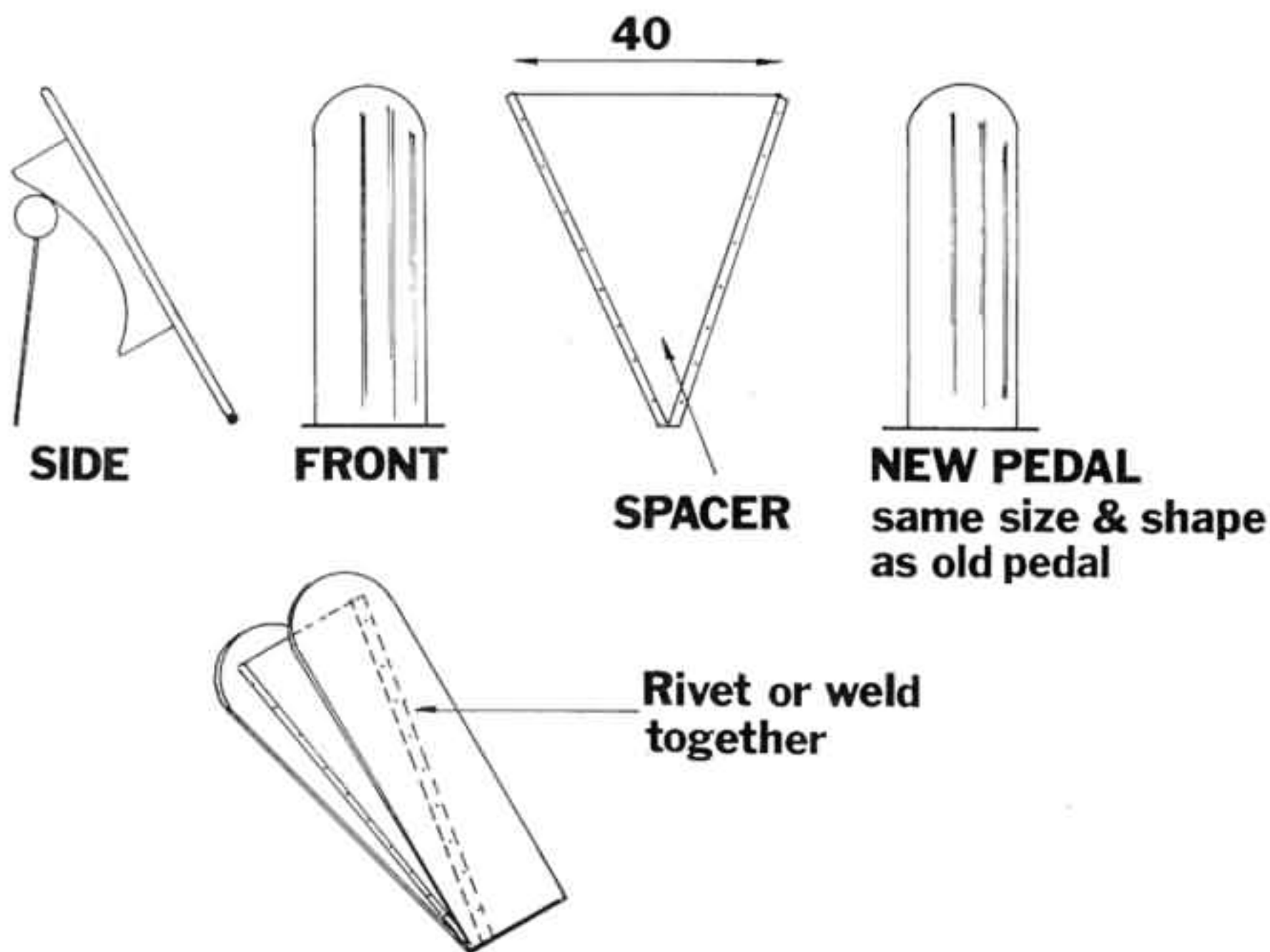

### BRAKE & CLUTCH PEDALS

This really depends on the driver's feet. Sit on the chassis with your heel on the floor pan and see how much the pedals need shortening. This is done by cutting off the pedal head, shortening the pedal and re-welding the pedal head back on. (THIS MUST BE WELDED CORRECTLY).

### THE HANDBRAKE AND HEATER CONTROLS

Having moved the gearlever back, the handbrake will be much too long and will require shortening. STRIP the ratchet assembly from the handbrake leaving just the lever and ratchet engage rod.

Unscrew the handbrake ratchet button and withdraw the rod through the rear of the lever.

Now work out how much the lever needs shortening (this will depend on how far back the gear lever has been moved).

The hand brake lever must be cut by the same amount as the ratchet rod (see Fig 6). These must now be welded back together and rebuilt.

# HANDBRAKE SHORTENING

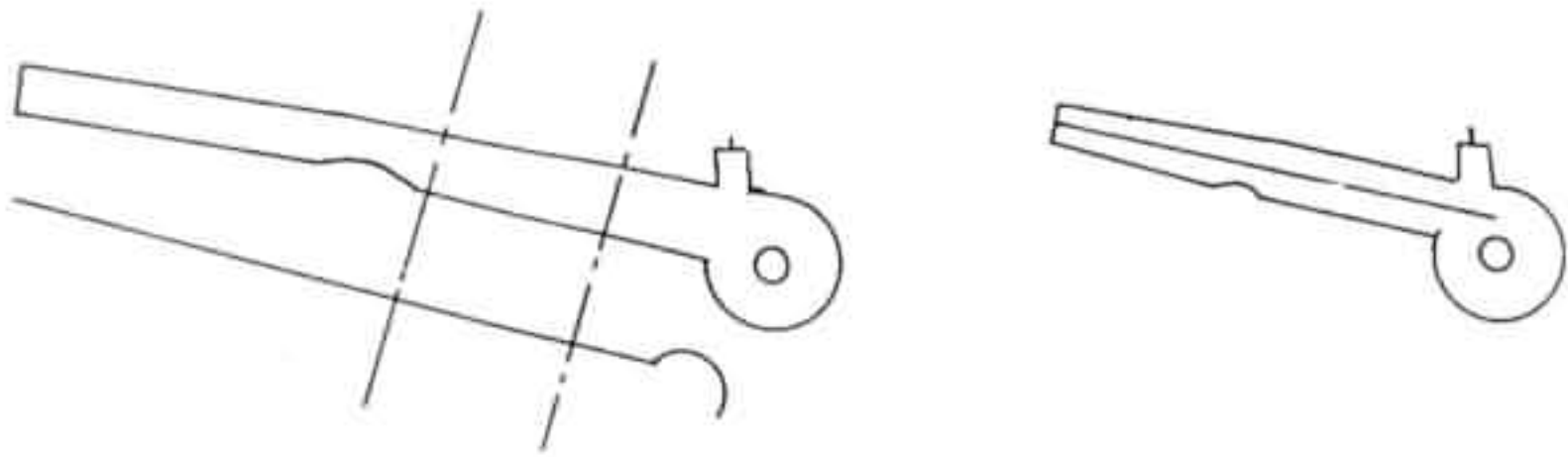

FIG. 6

## THE HEATER CONTROL LEVERS

One of the levers has a cable which runs to the heater exchanger units. This one is kept. The other lever control is the rear foot level outlet control. This is removed and discarded along with the cable guide tubes which emerge either side of the tunnel. These can be chiselled off quite easily (the old battery clamp bar can be removed also).

## FRONT SUSPENSION AND STEERING

Because the steering wheel is much lower on the NOVA than on the Beetle it is necessary to carry out a few small modifications.

1. The steering box is fastened to the front top torsion tube by a clamp and two bolts (17mm) which have lock tabs to prevent them coming loose. The steering box also locates onto a small lug on the tube. The first stage is to remove the steering box and grind off the lug. Now refit the steering box using new lock tabs (VW part No. 111 415159). Leave the box loose as it can not be lined up with the steering column until later.
2. The longer one of the two track rods will now foul the centre back bone with the steering box in its new lower position. A small modification must be carried out on the tunnel. A one metre long piece of scaffold tube, a powerful blow lamp and a large hammer are required for the job. First check that the old petrol feed pipe is empty (runs through the tunnel), then warm up the tunnel (see Fig. 7). When the tunnel is warm rest the tube on the chassis and give it several heavy blows with the hammer until a 30mm depression is created. Now rebuild the steering, as standard, leaving the steering box loose.

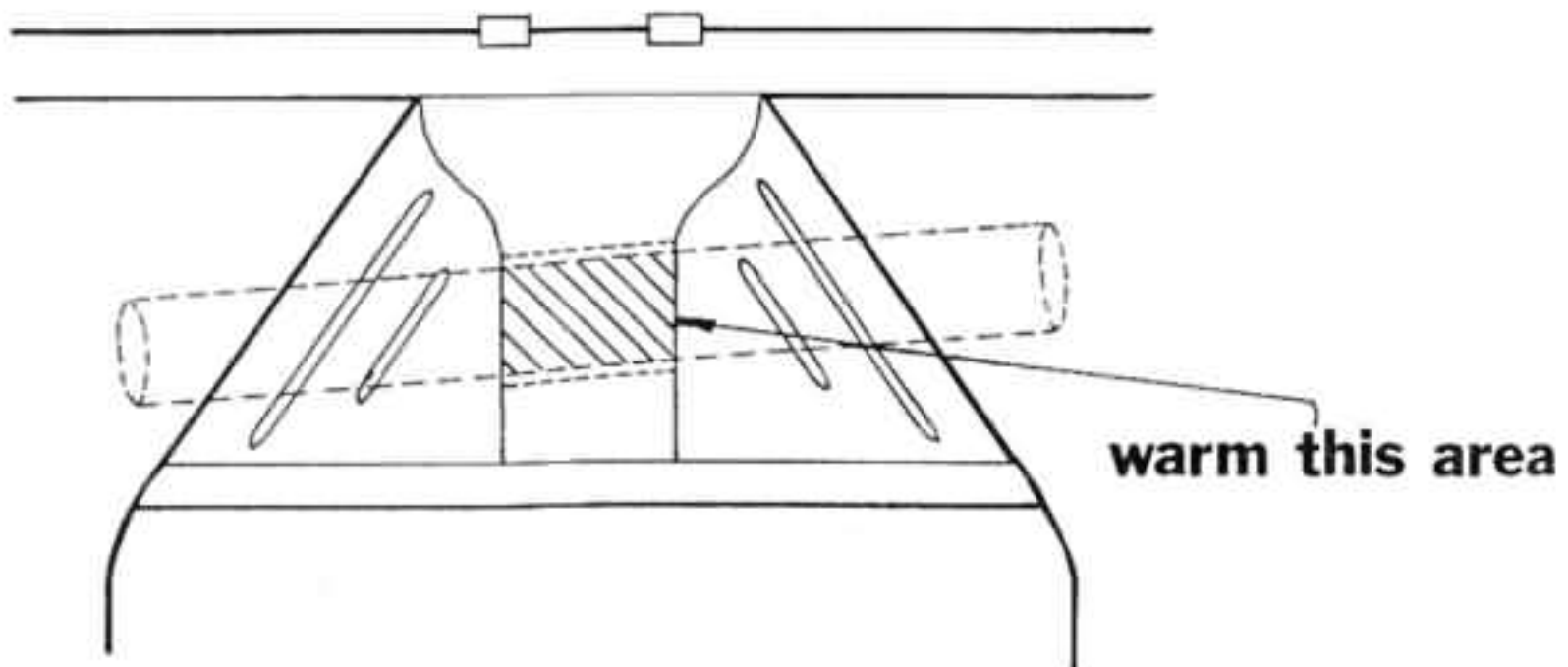

FIG. 7

## RECEIVING THE KIT

Upon receipt of the kit check its contents thoroughly and make sure any components missing are noted in the 'to follow' column on the delivery note. The best way to build the car is as follows.

Obtain some woodwork type 'A' frames and prop up the body (on the mounting flanges). It is now possible to fit the following parts whilst working in comparative comfort.

## THE PETROL TANK AND FUEL SYSTEM

The petrol tank must be new as a requirement of law. The actual tank part number is 113201075AD and was fitted 1972 onwards. It is fitted in much the same manner as the original tank, in that once it is placed on its supports (see Fig. 8) it is clamped to the support using the original tank clamp washers. Once the tank is fitted the fuel system can be connected up. For this it is necessary to purchase the following. Filler cap (check Nova prices!), Austin 11/1300 fuel filler pipe (scrapyard). For this you will also need 60cm of 20mm internal diameter (I.D.) petrol proof pipe similar to that used on the V.W. filler system, 2 jubilee clips to suit, a 40mm piece of 20mm outside diameter (O.D.) steel tube and the remains of the V.W. filler system and the 3mm I.D. tube (vent) from the small outlet on the side of the old tank.

First, drill the hole for the filler cap in the O/S rear wing, far enough back as to be outside the wheelarch. Now examine the cap. It will be noted that the pipe which will connect it to the tank is threaded for approximately 10mm and is fitted with a large fixing nut and lock screw. Remove this nut, position the cap in the hole in the back wing, refit the nut and tighten the lock screw.

The main tank filler can now be fitted. Offer up the 11/1300 pipe between filler cap and tank neck. It will be noted that the pipe does in fact need bending slightly. This can be done by warming.

The tank vent take off pipe must now be fitted. This is the 20mm steel pipe. A hole should be cut in the main pipe and the take off pipe welded in (see Fig. 8). The pipe can now be fitted using the original V.W. rubber pipe collars and jubilee clips. The 20mm pipe should also be fitted with jubilee clips. The 3mm I.D. expansion pipe from the small outlet on the side of the tank can now be fitted. This pipe runs over the top of the window tunnel (above the tank level) and then to within 15cm of the ground. The engine feed pipe must run into the engine compartment through the bulkhead avoiding the clutch gear (a grommet must be fitted to prevent chafing between pipe and bulkhead). The fuel system is now fitted.

FIG. 8

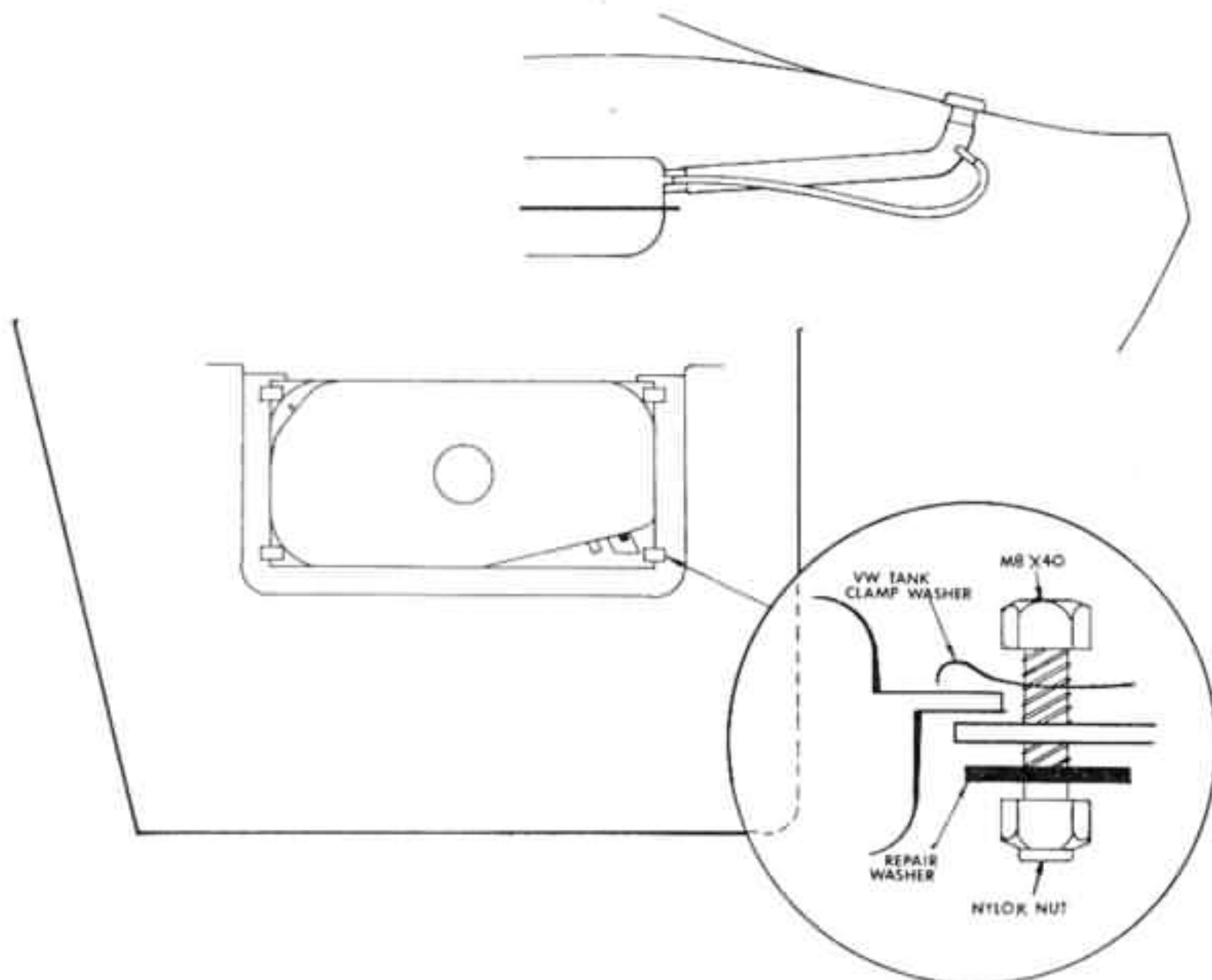

## THE HEATER SYSTEM

The Nova uses the original heat exchange units which must be in good working order and free from gas leaks etc. The piping for these is available from NSC in black steel reinforced plastic ducting. You will also need 2 metres of V.W. 50mm air hose and 2 Fiat 131/132 dashboard corner air vents and pipes (scrapyard). The large bore pipe is fitted first. It runs from beneath the fuel tank (level with the gear box bell housing) forwards towards the rear wheel arches and then through the side bulkheads through the reinforcing plate then forward under the glove box cut out and terminates level with the glove box cut outs. This is the same both sides. The Fiat vent holes can now be cut out. The vents can not be fitted at this stage.

FIG. 9

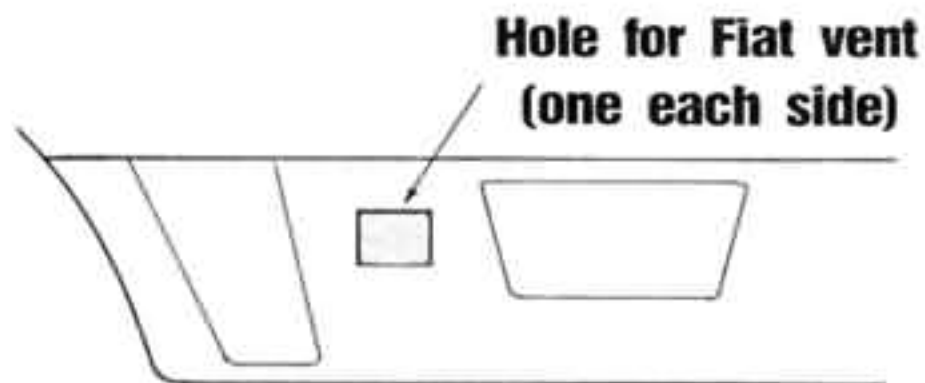
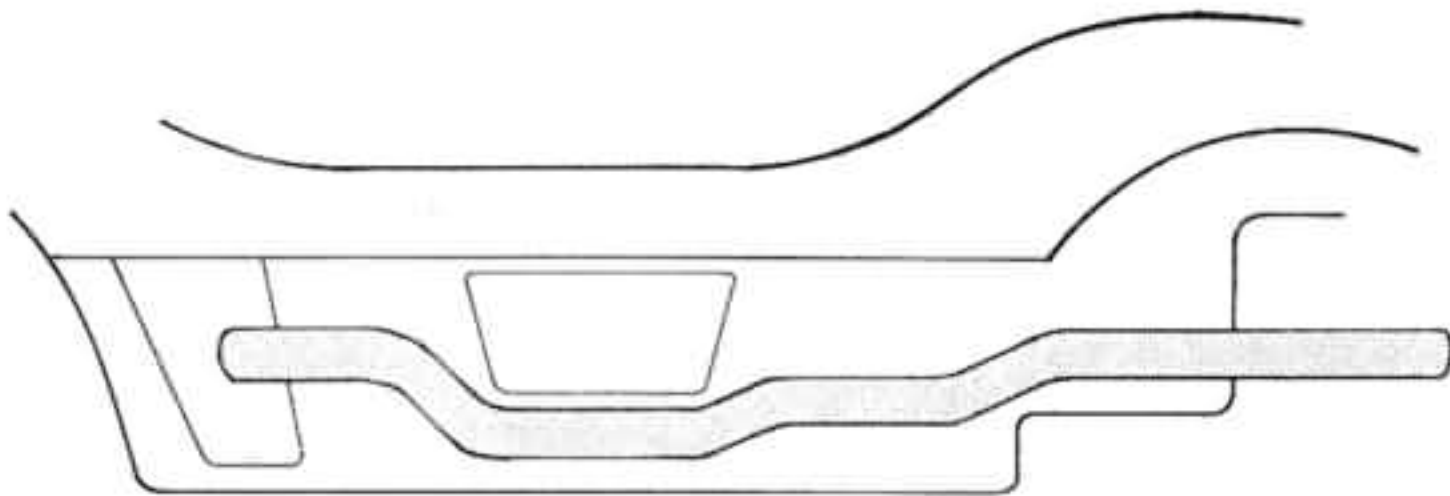

## DE-MIST SYSTEM

Things needed for this stage are 2 × 1m 50mm VW airhose, 1 litre resin and suitable amount of activator and 4 sq metres of 1oz chopped strand fibre glass matt.

The demist system is basically a long pipe running underneath the main dash moulding. It is glassed into a trough in the moulding (see Fig. 10).

1. Turn the main dash panel over. It will be noted that there is a trough formed in the bottom of the moulding. This is where the air hose is to be fitted.
2. Have a trial fit with the pipe and bend it to as near shape as possible.
3. Mix the litre of resin (as per manufacturers' recommendations) and cut the glass matt into pieces 15 x 10mm (about 20 pieces will be needed). Place the air hose in position and damp with resin all except the last 15cm at either end. Now place the matt strips across the pipe and damp them thoroughly (a normal paint brush about 2" is best for this job). All air must be removed by stippling.
4. Leave to harden.
5. When the glass has cured, turn the dash right side up and drill a row of 10mm holes in the dash through into the pipe. In order to connect the demist up it is necessary to carry out a small modification to the Fiat vents.
  1. Cut the remaining metre of air hose in half.
  2. Find a piece of steel tube approx 50mm in diameter (the old V.W. filler pipe works well). Clamp the pipe on a pair of mole grips, warm up the end (not red hot) and melt a hole into the pipe vent assembly. Now fit the end of the air hose into the hole approx 13mm and seal with mastic. Put these assembled parts to one side.

FIG. 10

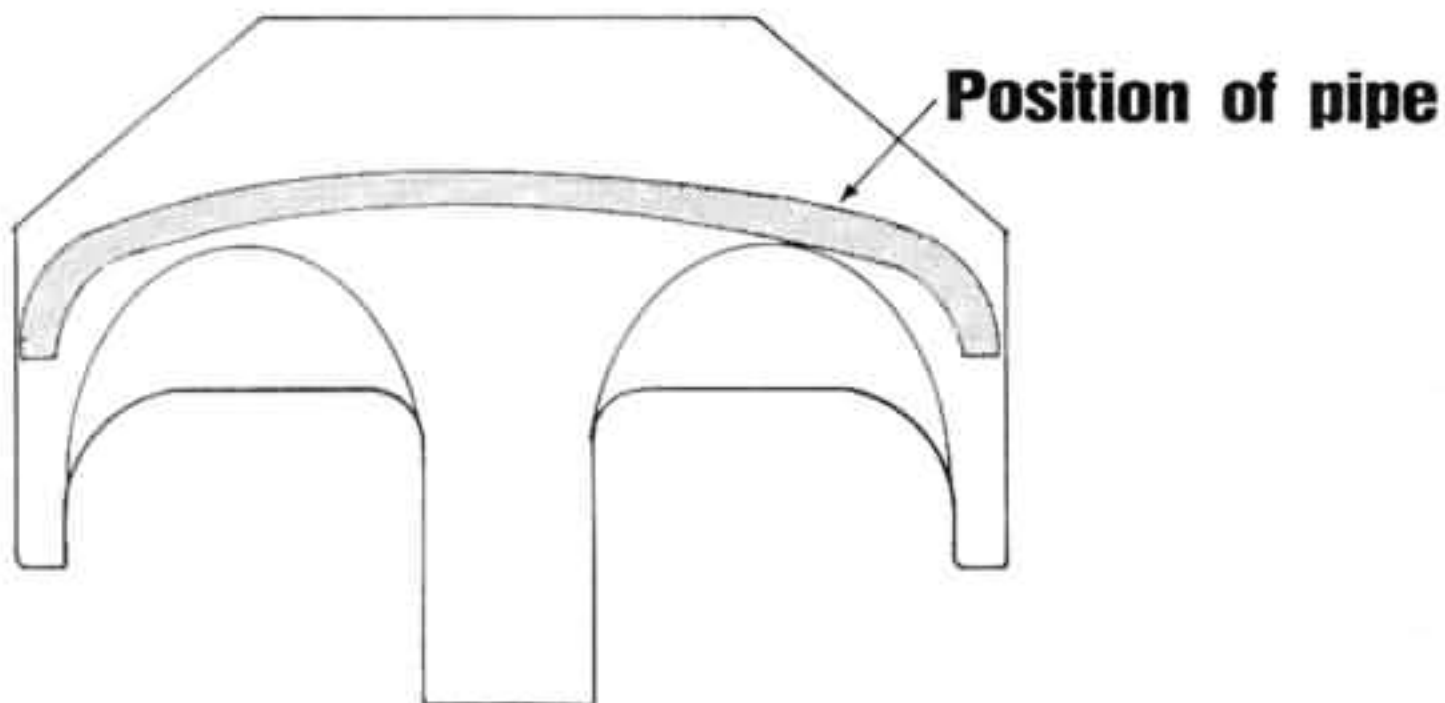

## WIRING

This is the part which upsets most of our customer kit builders and really it is one of the most interesting stages. Basic methods learned now will be invaluable in the future. If you are completely ignorant of auto electrics, buy a book on the subject and learn as much as possible about basic circuits etc. On the other hand if you are expert enough to design, build and fit your own loom, then the rest of us will catch up later.

The Nova wiring loom is designed specially for the vehicle and to make life easy for the not so expert electrician, it already has all connections fitted and the fuse box wired in and it comes with complete instructions which are reproduced later in the manual.

### WIRING INSTRUCTION (FITTING ONLY)

The secret of success is in the positioning of the loom. Providing you get this right, the rest is easy.

The fuse box is mounted in front of the driver's glove box (leave room above it for the flat vent) and is fixed by screwing it to the body.

The rear harness then runs backwards along the body clipped every 30cm by a plastic tie wrap purchased from electrical wholesalers in 100's (x 15cm). These are fitted by drilling two holes one above the other passing the clip through one hole and out of the other and then through the clip.

A hole must be cut in the rear strengthener above the heater pipe and the rear section passed into the rear wheel arch. Half way across the arch, the wires for the tank and starter motor will branch off the main loom. This branch should be lined up with the starter motor. The main loom will carry on towards the rear and then a hole should be cut for the engine wires to lead into the engine compartment.

The voltage regulator and hydraulic roof relays wires (if fitted) terminate just inside the compartment and these units must be fitted to the vertical face of the bulkhead. The engine wires then continue to the fan housing where they are held by the V.W. wiring clips. They travel across the engine to the various ancillaries, then from the engine to the hydraulic pump (if fitted).

The rear light wires are not fitted at this stage, but their multi pin connector should be brought through with the engine wires, from the fusebox, forward.

The dashboard wires must come through the body. Leave these for now. The front end wires must go through the front strengthener into the front wheel arch and be clipped as high as possible to avoid wheel contact.

The front harness will then run to the front O/S headlamp assembly. From there the loom runs across the body shell behind the spare wheel compartment, to the N/S headlamp assembly. Where the loom passes through a bulkhead etc., it must be sealed with a silicone rubber sealant to prevent chafing on the fibreglass.

Before we go any further we can:-

## FIT THE BODY TO THE CHASSIS

This is a very important step but is quite simple.

1. Fit the bodyshell onto the chassis and check to see where it fouls. The most likely places are at the front, the box for the throttle cable and the brake pushrod. After some glass fibre has been cut away the body should sit snugly onto the pan (see Fig. 11).
2. When you're satisfied that the mounting flange is sitting on the chassis, the body can then be aligned. This is accomplished by hanging weights on string from all four wheel arches like plumb lines and measuring to a fixed point on the chassis e.g. hubs. When the shell is aligned (give or take 10mm) you can drill 8mm holes in the body mounting flange from underneath the chassis (through the original mounting holes). Now remove the body and use epoxy mastic (cartridge form) to lay a 12mm bead of sealer around the floor pan. Remember the back corners are round not square. Now place the old V.W. floorpan gasket on top of the sealer. If your seal is useless the V.W. part number is 113 701 605. Don't worry if the seal is sponge rubber instead of normal rubber. It is just as good. Alternatively NOVA Sports Cars Ltd can supply a seal. Now apply a similar amount of mastic on top of the seal.

Carefully lower the body onto the chassis and try not to move the seal too much. Take a pointed instrument and poke through the holes in the body, and through the seal and finally the chassis. As you go around push an M8 x 40 high tensile set screw and large repair washer through the hole. When all bolts are in position climb underneath and put the V.W. channel washers and a nylock nut on the end of the thread and tighten up to 25lb ft. (these bolts must be re-tightened in 3-4 days). The front body mountings must now be assembled. For these you will need 5.0cm of 15mm OD steel tube. The two fibreglass brackets supplied, can now be fitted to the rear of the body (see Fig. 12). First, fit the bracket to the bulkhead with M8 x 30 bolts/washers combination and then drill from above through the bracket and then fasten the bracket using the chassis captive thread and one M10 x 40 bolt and washer (Fig. 12).

**Cut out clearance for  
throttle box**

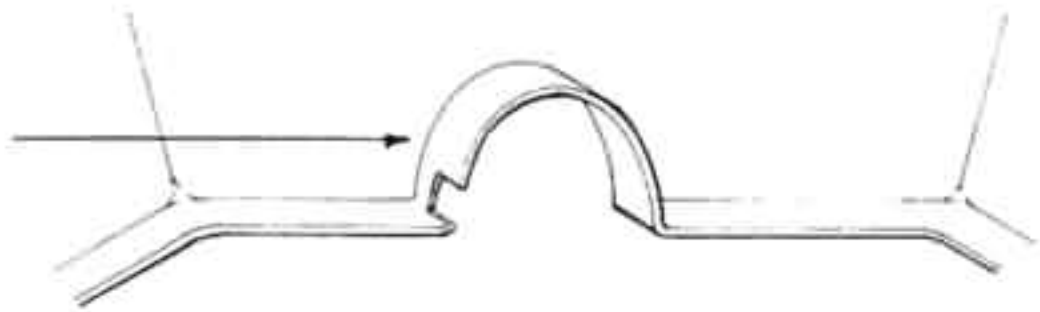

**Cut out clearance for  
brake pushrod**

FIG. 11

FIG. 12

## FRONT BODY MOUNTINGS

**Large repair washer**

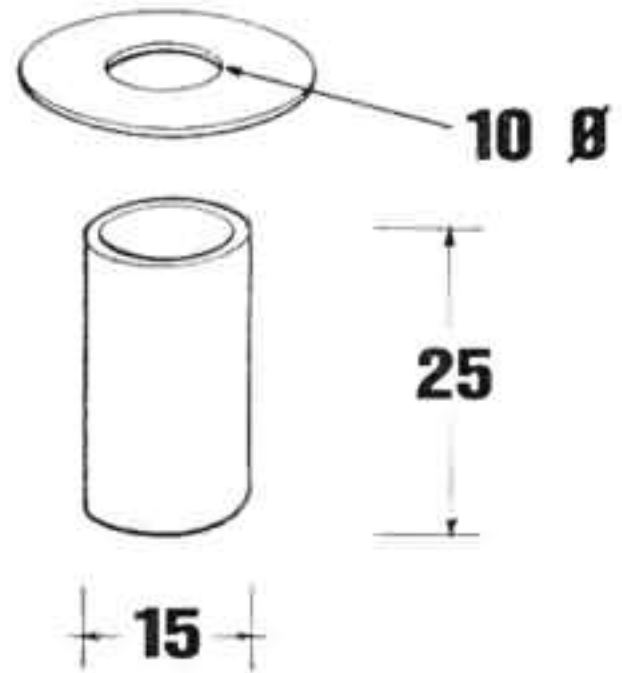

## REAR BRACKET

**(handed GRP)**

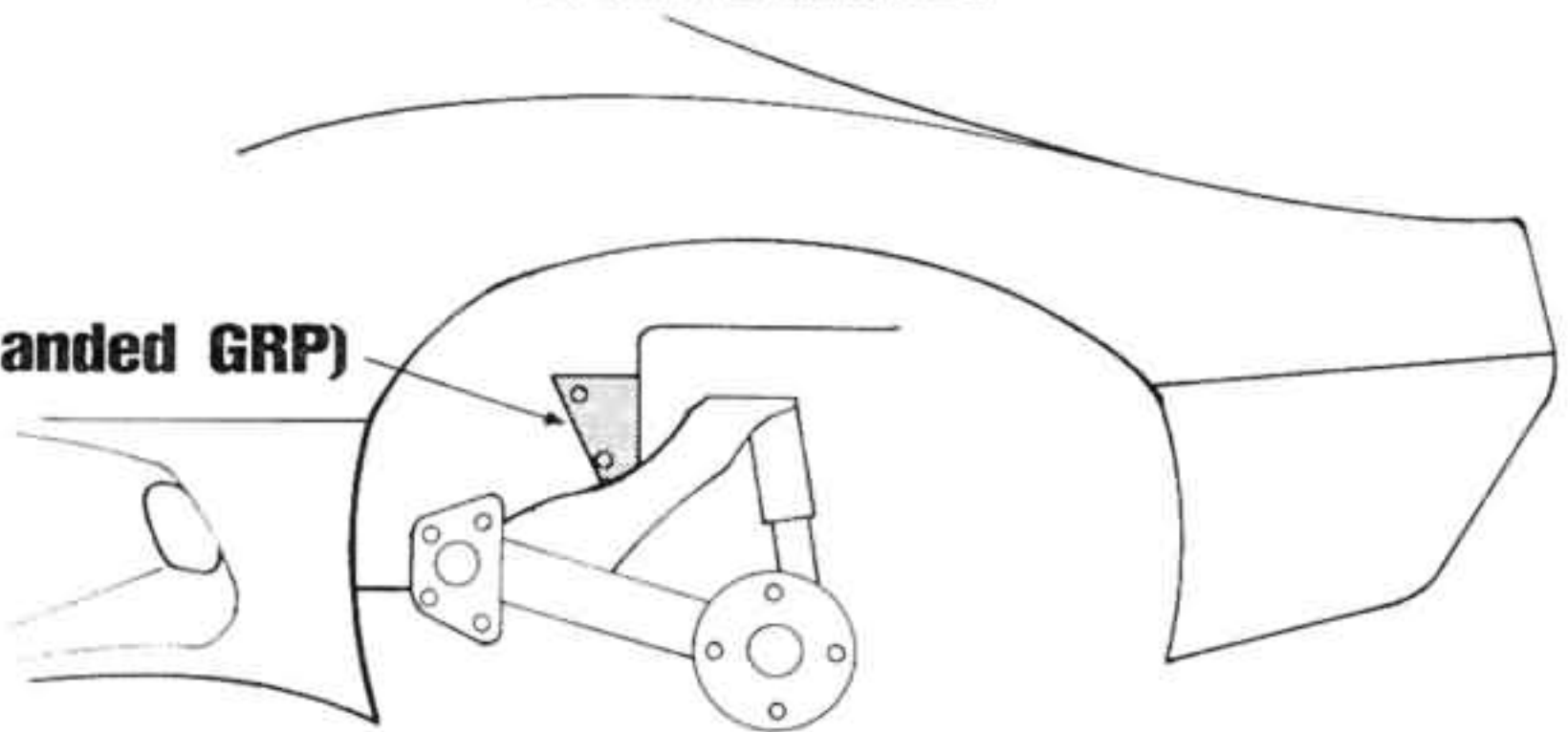

## CARPETS

Using NOVA supplied set.

Certain parts of the carpeting must be fitted now as the next step involves fitting the dash main panel.

The backbone tunnel should be covered along with the side panels. These are fitted by using Dunlop Thixofix adhesive (follow instructions on can). Refer to diagram for carpet position. The rest of the carpets are fitted later.

### Carpet

**this part of the tunnel**

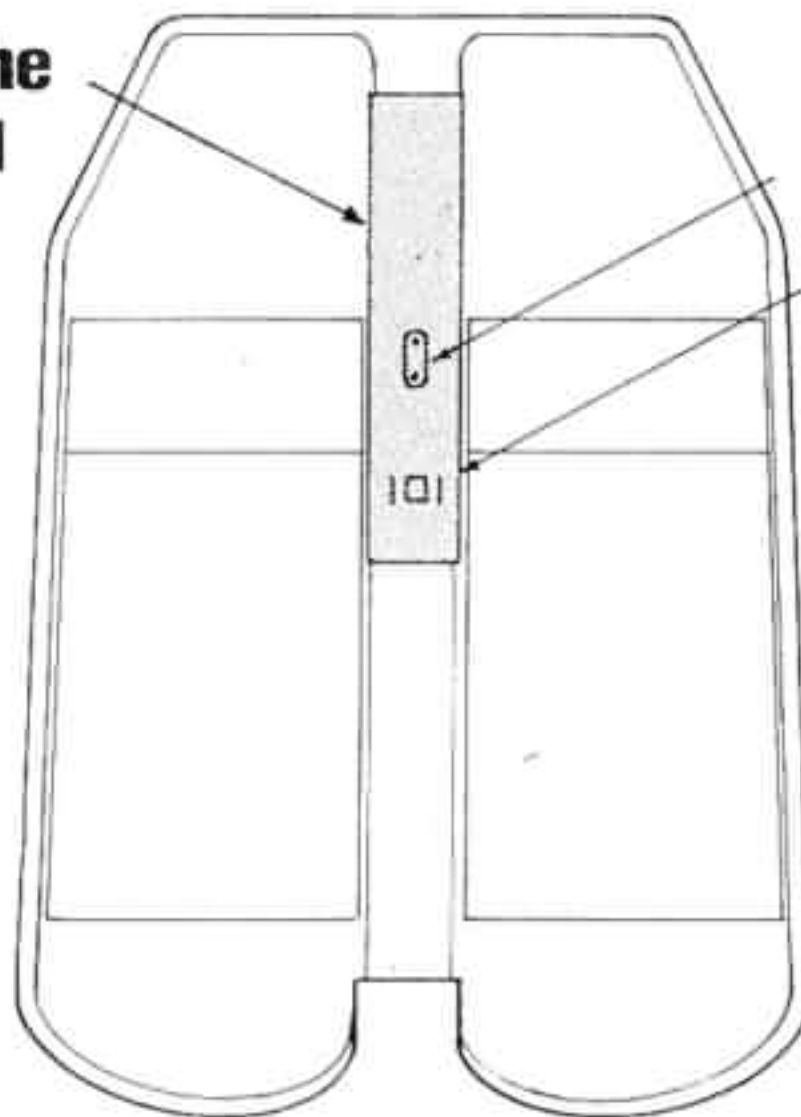

**Gear lever mounting**

**Hand brake mounting**

FIG. 13

## THE MAIN DASH AND STEERING COLUMN

The main dash is a very important part as it supports the steering column. Trial fit the dash into position (gearlever removed). The front edge of the dash should be 26mm from the top edge of the body and the console should be pushed hard down to the tunnel (see diagram page 15) with masking tape. Mark the positions of the front edge and console and remove dash. Now refer to diagram on page 16 and cut away a slot large enough to accommodate the steering column in the centre of the flat face. A steel plate must be manufactured and bolted to the dash before the column is fitted. In order to cut the hole for the gear lever accurately, a measurement must be taken from the tape left on the chassis during the trial fit (see diagram page 15). Once this distance has been measured, the centre console can be cut out (square approximately 10cm x 10cm) and a Ford Cortina Mk III gearlever gaiter (breakers yard) can be inserted from underneath.

The dash panel is now ready for fitting. First re-assemble and adjust the gearlever assembly and then fit the dash as before leaving approximately 26mm difference between the dash front edge and top edge of the body. The gear lever should come through the gearlever gaiter and the console can be pushed down hard against the tunnel.

The dash can now be bolted in using M8 x 30 set screws/nuts and large washers either side (see diagram page 15) and self tapping screws. Bolts A2, A3, A6, A7 must be inserted from inside the front wheel arches before the dash is finally fitted the fresh air blower (Hillman Imp) must be installed (see Fig 17).

FIG. 14

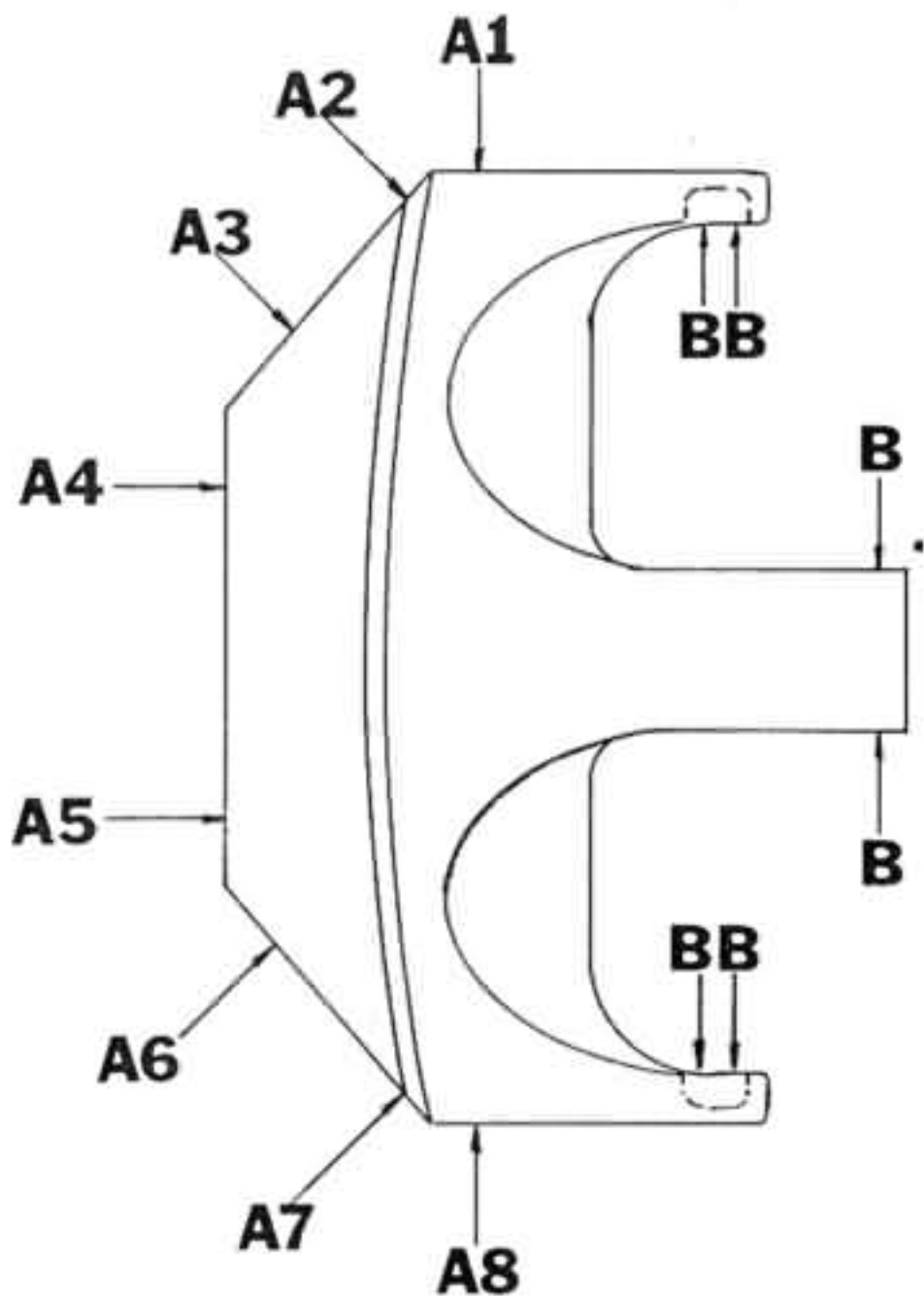
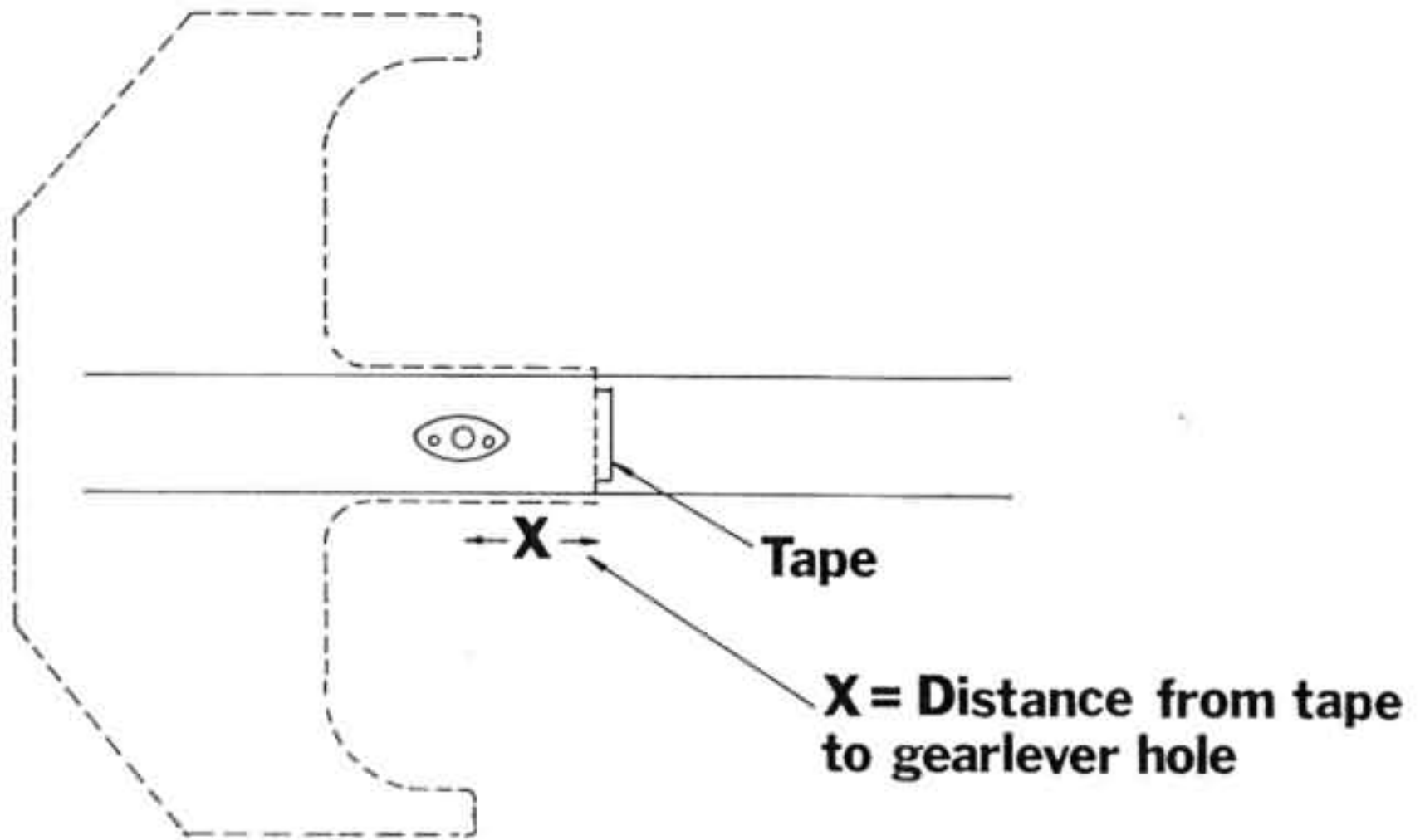

**A) M8x40  
SET SCREW/NUT  
WASHERS**

**B) SELF TAPPING  
SCREWS**

FIG. 15

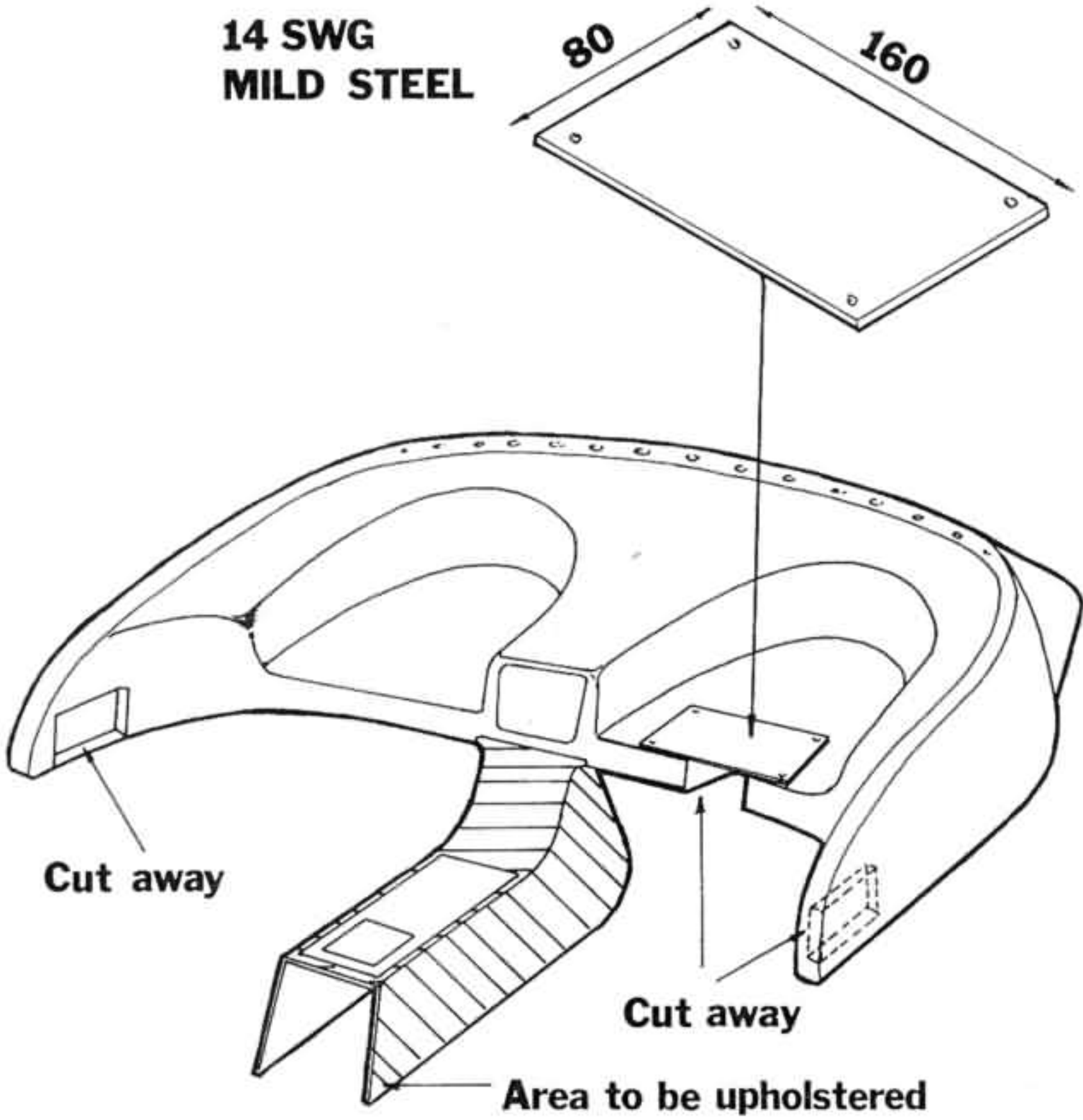

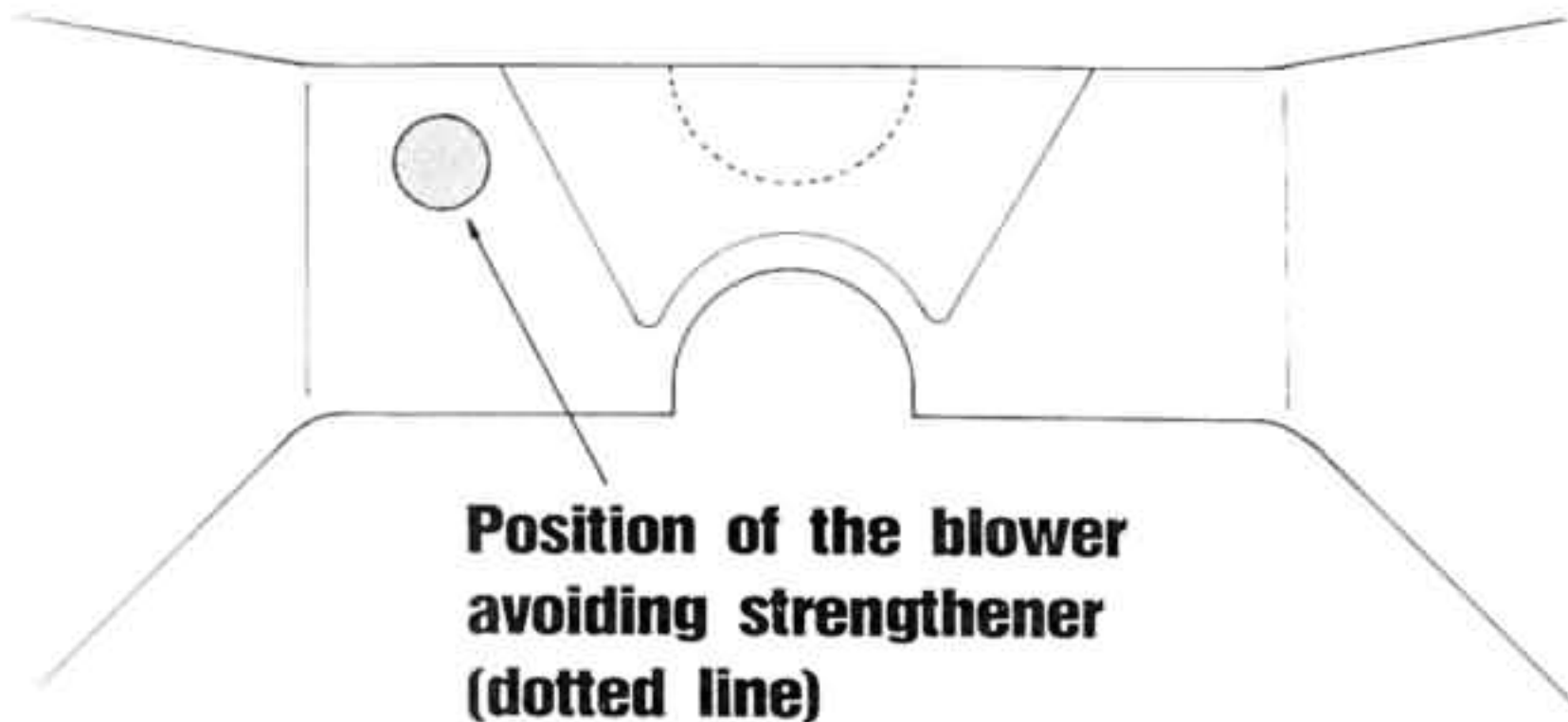

### THE STEERING COLUMN

The steering column is quite simple to fit but as the position of the dash can be different from car to car each must be fitted using measurement from the car.

First obtain a  $\frac{1}{8}$  diameter welding rod this is used to roughly set the position. Looking from the side of the car roughly set the steering box to the angle of the column. Supporting one end of the welding rod in the centre of the slot previously cut in the dash, drill a  $\frac{1}{8}$ " hole in the bulk head where you think the column will need to be, then push the rod through climb out and see how far you have missed the steering box by. If you have been lucky you may have got it first time, if not drill another hole until the end of the rod hits the steering box. Once this has been achieved drill a hole the same diameter as the steering column outer tube, in the bulk head. The column can now be offered up to the dash. If everything is correct you can fix the column using the V.W. BRACKET. This is done by holding the column up against the dash and drilling two 8mm holes from underneath through the dash and the steel plate fitted previously. The steering coupling can now be connected (it is advisable at this stage to replace the rubber coupling) and the protruding outer column glassed to the body. The column must be free from tight spots in operation and this can only be achieved by accurate measurement. Holes can now be cut in the dash and the wiring loom pulled into the steering column area, also the demist pipes from the vents can be connected to the demist tube previously fitted.

## INSTRUMENTATION

The instruments can now be fitted to the upper dash panel. First, the dash top panel must be trimmed to fit the front edge of the dash so as not to obstruct the demist holes. Then, the slot for the steering column should be cut. When this has been done the dash should be upholstered (without padding). This job should be entrusted to a trimmer, or alternatively NOVA Sports Cars Ltd. can provide ready trimmed panels to your specification. When this has been completed the holes for clocks, switches, etc. can be cut out. The standard clock layout (see diagram below) is very good but you can change things about as long as you do not move the large clocks too far (10mm) from their normal position (see diagram). The clocks and switches can then be fitted to the dash. The centre vent is a little more complicated. The rear part of the vent must be carefully cut off (see diagram page 19) and kept as this will be used later. The hole should be cut as per diagram below. Two strips of mild steel are now required (see diagram page 19). These are rivetted to the vent and then self tapping screws and caps used to hold them and the vent against the dash.

The piece cut off earlier can now be glued to the front of the vent to hide the edge. The vent pipe is then connected to the vent from the blower. The dash is then wired according to the instructions.

The rest of the carpets can now be fitted in the same way as before. It will be noted that the rear section is split in two parts. This is to facilitate easy fitting. The two pieces are fitted separately to follow the contours of the body. When they are fitted, there will be an overlap in the middle which can be cut off and a trim manufactured by upholstering a strip of mild steel approximately 1m x 3cm in the same material as the dash. This can then be screwed over the joint (using screw caps of course).

FIG. 17

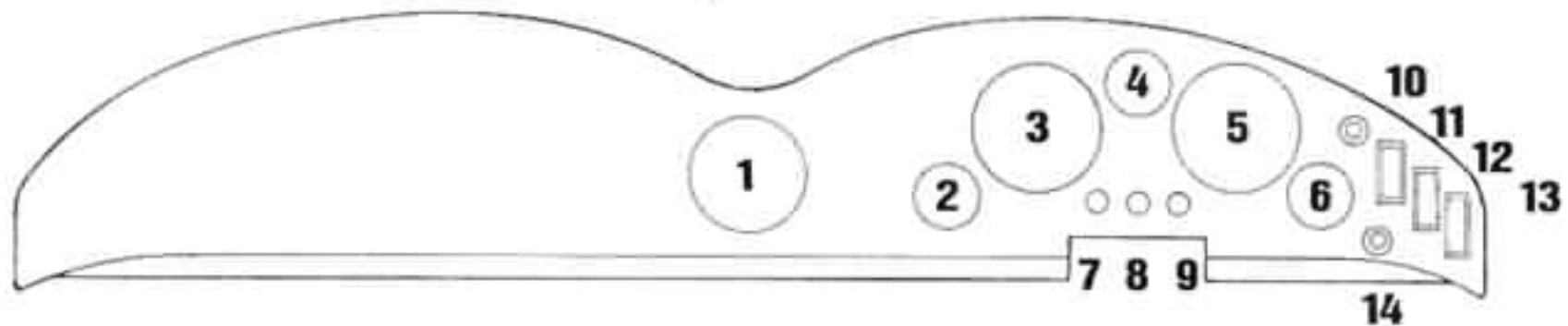

- |                      |                   |
|----------------------|-------------------|
| <b>1 Centre Vent</b> | <b>8 Oil</b>      |
| <b>2 Volts</b>       | <b>9 Ignition</b> |
| <b>3 Tacho</b>       | <b>10 Washer</b>  |
| <b>4 Oil</b>         | <b>11 Lights</b>  |
| <b>5 Speedo</b>      | <b>12 Wipers</b>  |
| <b>6 Fuel</b>        | <b>13 Blower</b>  |
| <b>7 Beam</b>        | <b>14 Roof</b>    |

FIG. 18

**Cut here and use piece to trim front**

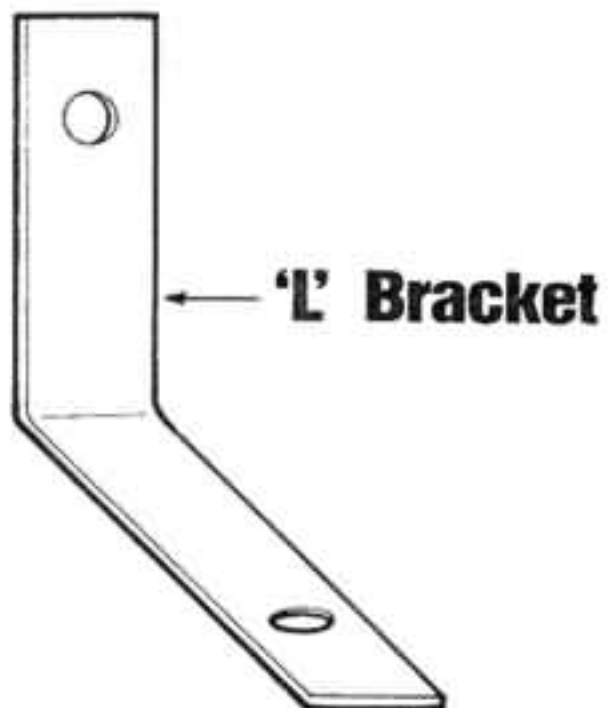
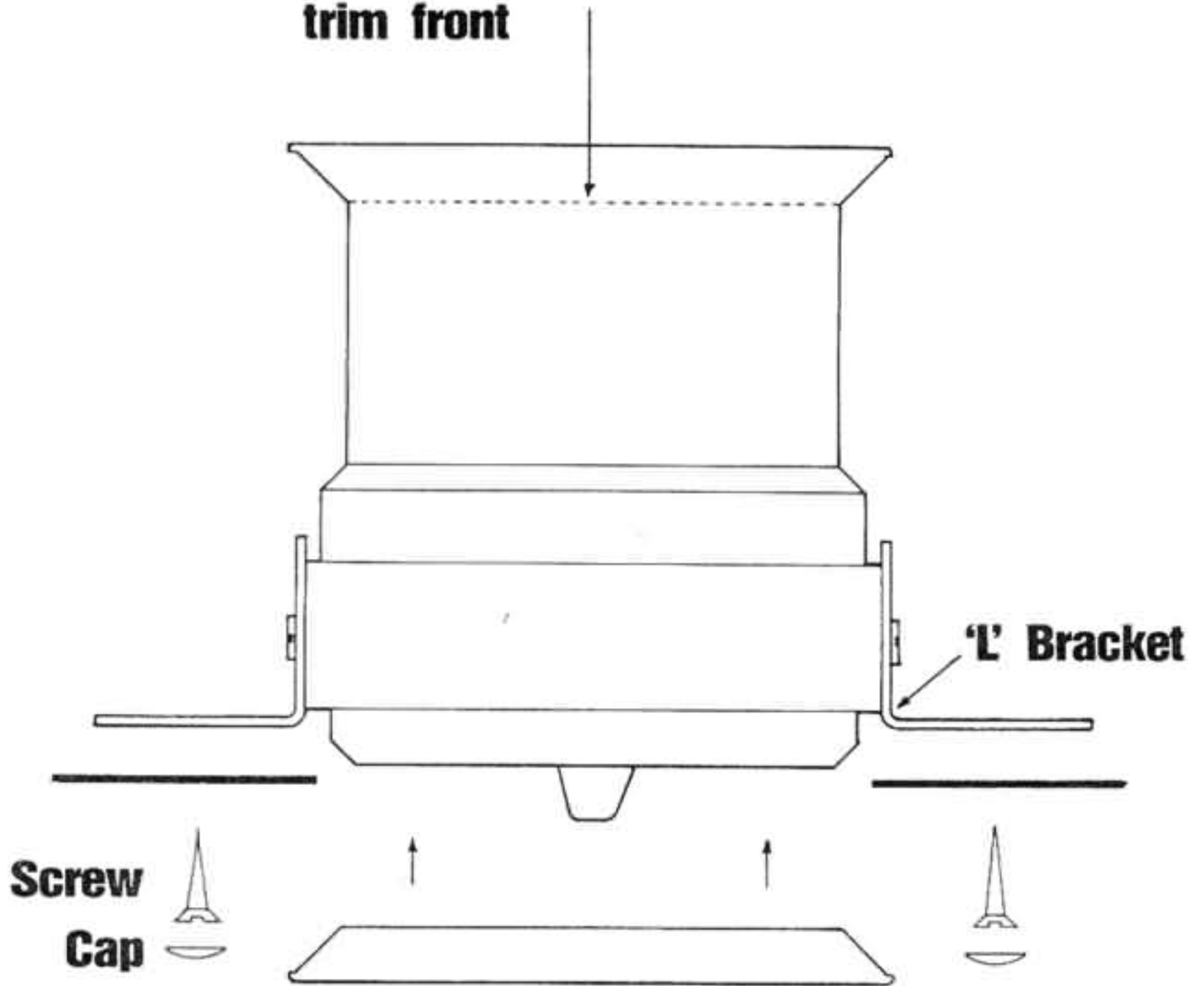

## REAR WINDOW TUNNEL

For the sake of a little time and money it is worth while having the tunnel covered. The rear window is fitted (check fit first) using a special sealant (available from NOVA Sports Cars Ltd) and must be masked up as per diagram below. The inside of the tunnel should also be masked. The sealant is applied to the perspex in a 8mm bead directly from the cartridge. This is then spread on the back. The tape is then removed from the coated side and the window is carefully dropped in. Sealer is then applied to the inside edge of the glass (quite thin) and smoothed around with the finger. Then the tape is removed from the tunnel and the sealer left to set. Once it has set the tunnel is pushed into the hole in the body shell and screwed (and caps) to the body.

A few small jobs are left to do outside the car now.

FIG. 19

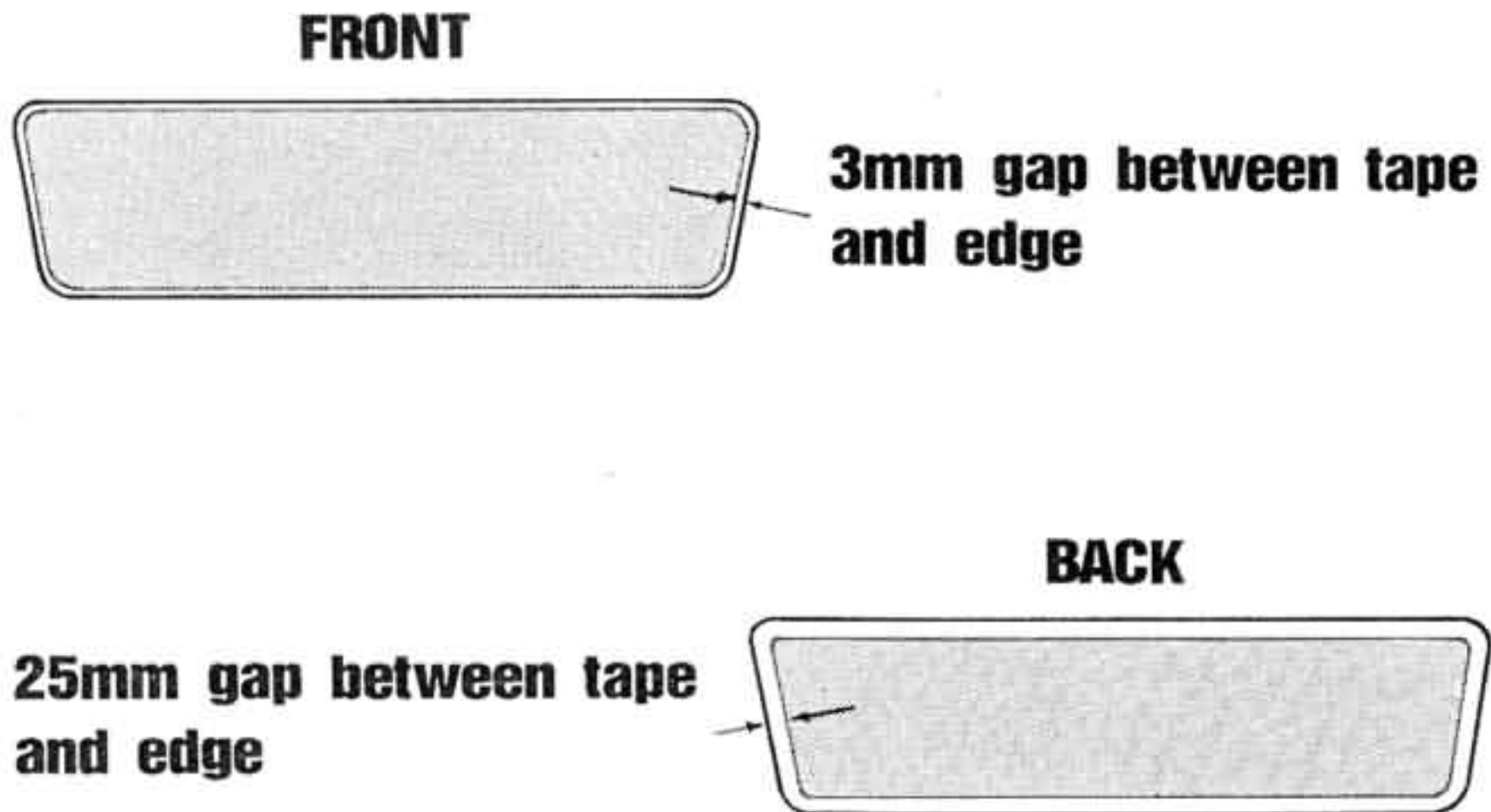

## THE BRAKE MASTER CYLINDER RESERVOIR

Can now be fitted using a stainless steel strap (20 x 2cm) formed as per diagram page 21 and rivetted to the body. The holes used to connect the reservoir and cylinder must be brake fluid resistant and connected in such a manner as to miss the track rods etc. Clips are not essential as these pipes are not under pressure.

## THE WASHER SYSTEM

Electric washers are used in the NOVA and loom already supplied has the wires 'built in'. The jet is positioned on the centre line of the bonnet 15cm down from the top edge. The reservoir bag and motor are fitted, as per diagram.

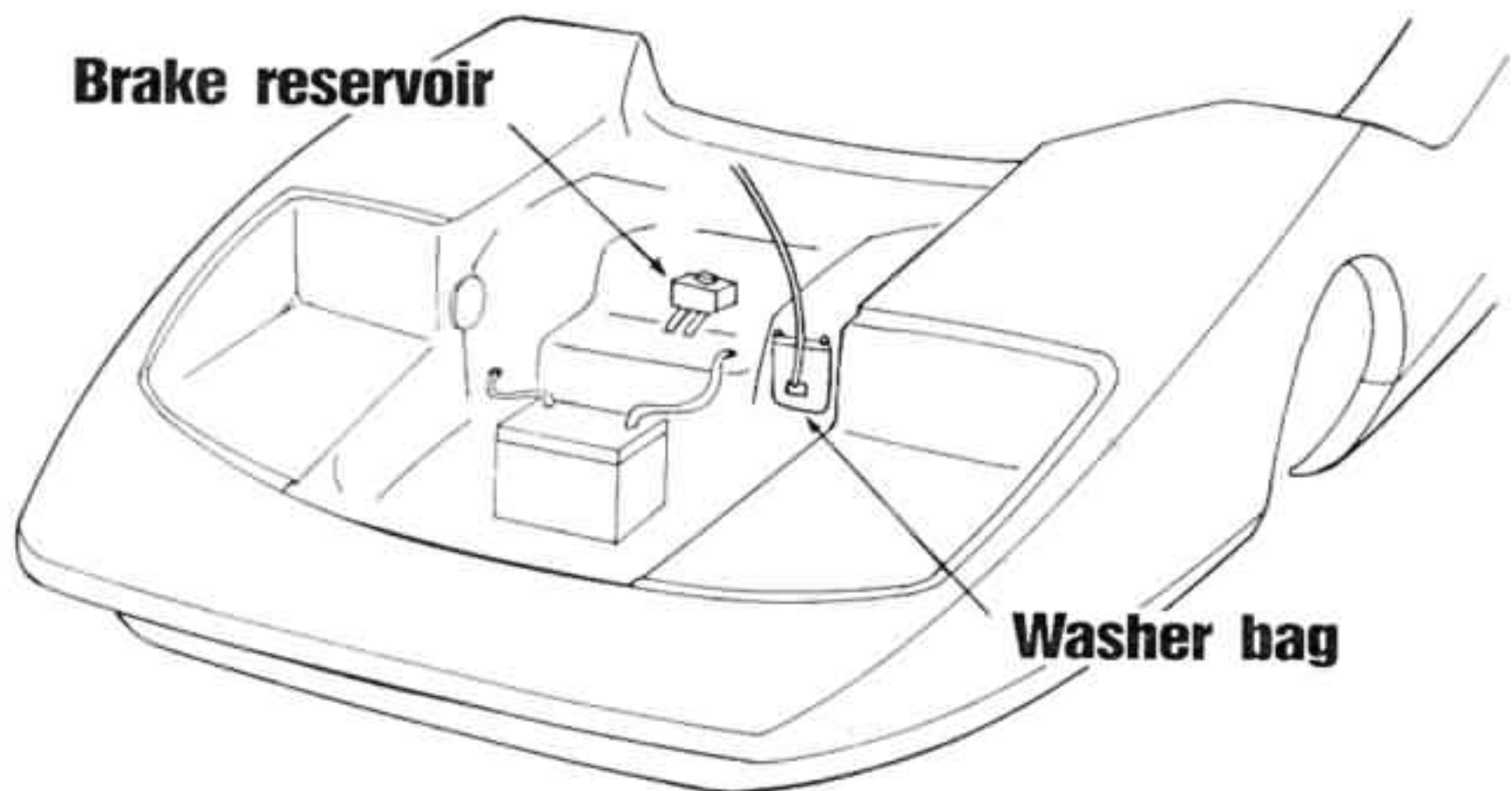

### SPEEDO CABLE

The V.W. cable is no good if you are using Smiths instruments (a special cable is available from NOVA Sports Cars Ltd). The cable is connected to the front N/S wheel. Again care must be taken that it does not foul steering or suspension gear. The cable should then travel through the bulk-head at the centre, just below the tubular strengthener and from there through the hole previously cut.

### WIPER MOTOR

The wiper motor supplied in the De-Luxe kit is a 2 speed unit equipped with self park, which enables it to return the arm to a park position, regardless of where the arm is, when the switch is turned off.

The arm itself is of a pantograph type as used on commercial vehicles. The fitting of this unit is quite simple. The wires must however be routed first. Start by drilling a 10mm hole in the bottom hinge plate just in front of the rear strut (driver's side) a 10mm hole should then be drilled in the front face of the driver's side rear strut, approximately 20mm above the weld, another 10mm hole in the front face of the same strut approximately 20mm below the weld, and a final hole in the canopy as diagram page 27. The wiper cable can now be routed from inside the sill, through the plate and tube using a stiff wire as a guide between the canopy skins. When this has been accomplished the motor can be fitted. The driven spindle goes to the driver's side and the M8 stud to the passenger's side. Find the middle of the roof 85mm below the bottom edge of the screen and drill a 8mm hole for the stud and a 10mm hole for the driven spindle. Using the parts supplied, clamp the motor to the roof, leaving at least 12mm of the stud showing above the roof and wire up the motor as per instructions. The arm blade assembly is fitted after the motor has been run and the self park position found.

### HEADLAMP COVERS

These covers should be painted with normal cellulose spray cans either black or body colour. Before they are sprayed, four 4mm holes should be drilled, one at each cover, approximately 7mm from the edge. They should then be masked up as per diagram page 22 and given 3-4 coats of paint. When fully dry, they can be fitted with self tapping screws (and caps).

FIG. 21

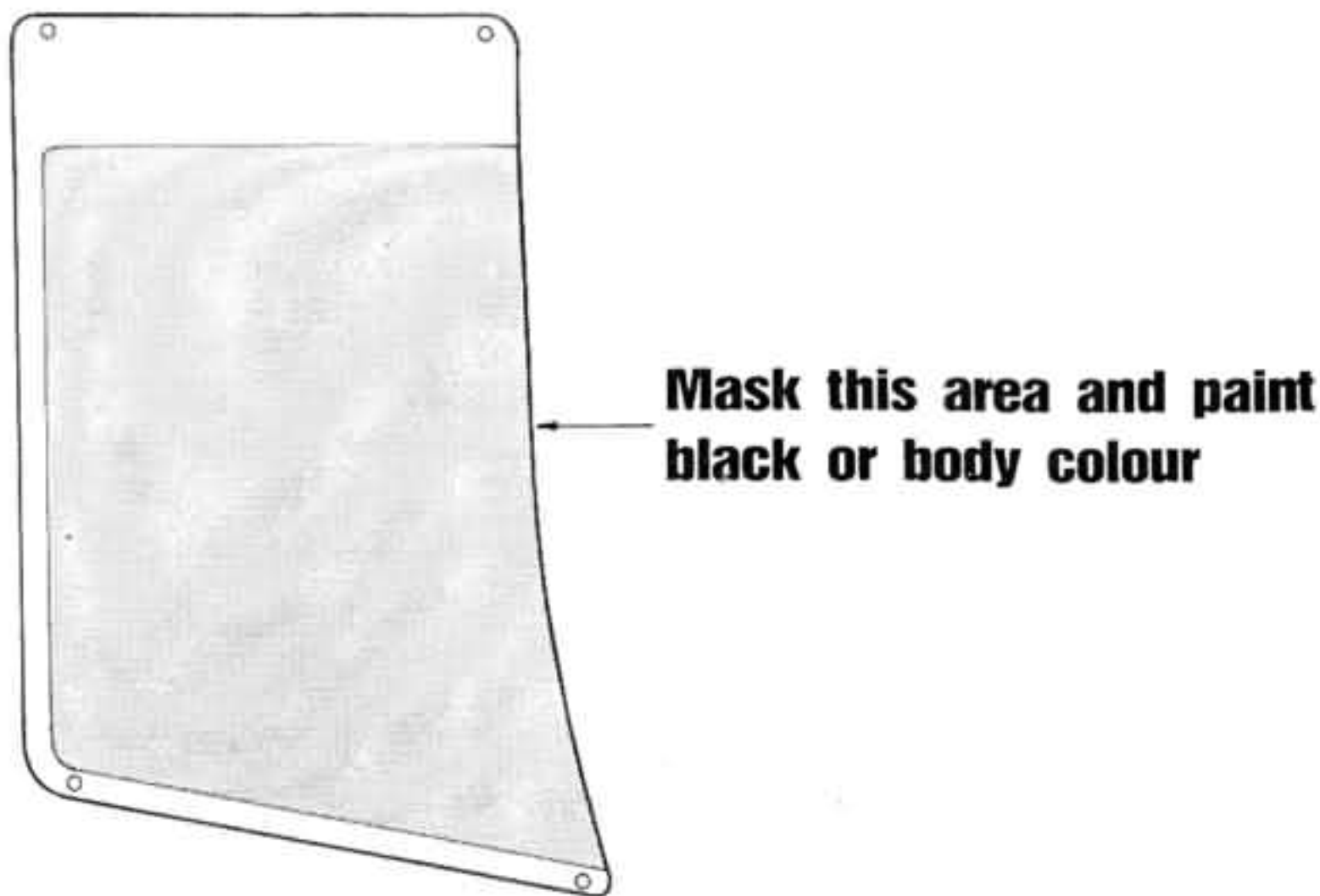

**Mask this area and paint black or body colour**

#### FITTING THE FRONT LOWER PANEL

The panel should first be clamped into position using mole grips. Masking tape markers should then be positioned as per diagram page 23 (3 each side). The tape is slit on the panel using the tape as a guide. The panel can then be refitted and bolted using M8 set screw/nut/washers.

As there is no access to the front, we must use a different method. It will be noted that a small ledge has been incorporated in the moulding. Drill a row of 6-10mm holes in this ledge. If you look through this hole you can see the panel flange. Drill 4mm holes inside the 6mm holes right through both flanges. This can now be fastened up using large self tapping screws.

#### FITTING THE SIDE SILLS

First 1 1/2" must be trimmed from the bottom of the sill. Working through the glove box, clamp the sills in position with the mole grips and using the tape method, find the correct position of the bolts. Approximately 5 bolts should be used.

When the sill is fixed, it must be glassed in either end (see diagram page 24). When the glass has gone off, paint it with underseal.

#### REAR PANEL AND BUMPER

The rear panel is fixed in the same method as the sides of the front tray (tape). The rear bumper must be trimmed to fit the rear panel perfectly.

The lights should now be positioned and marked out. The lamps are flush fit, but 2 small brackets per lamp must be made up to fasten onto the studs (see diagram page 25). Once the holes have been cut, the light panel should be painted matt black and then trim fitted (available from NOVA Sports Cars Limited).

The bumper is fitted as per diagram page 24, using the normal bolt/nut/washer combination.

### Fitting the NOVA panels using masking tape and drilling jig

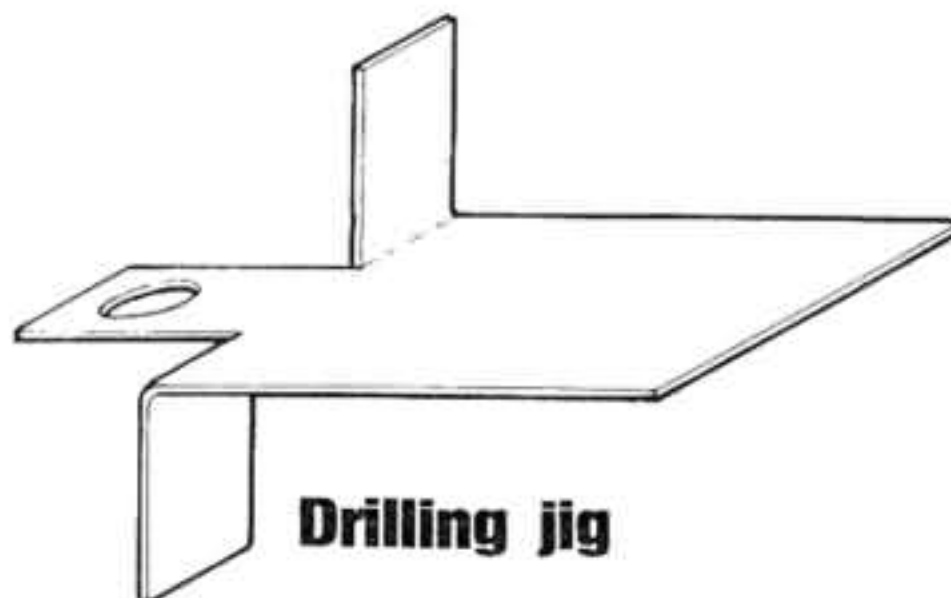
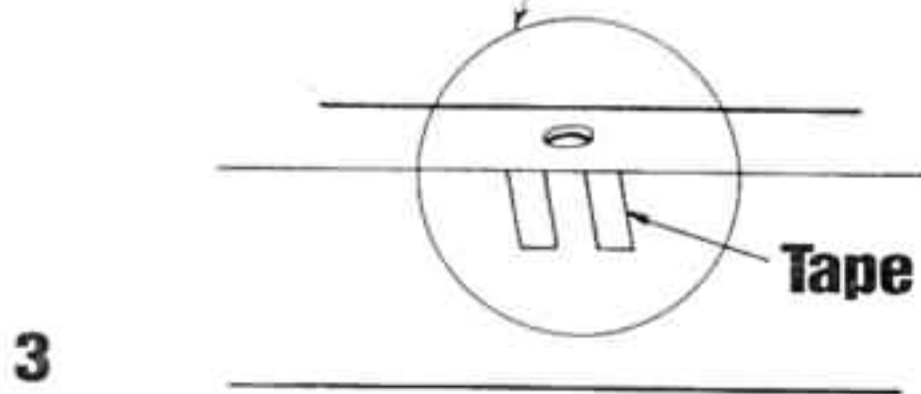
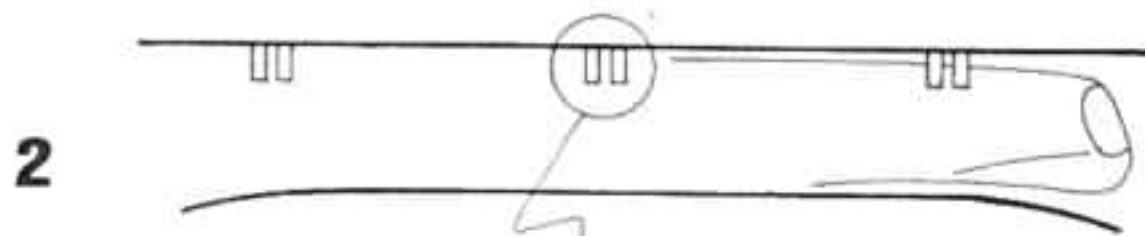
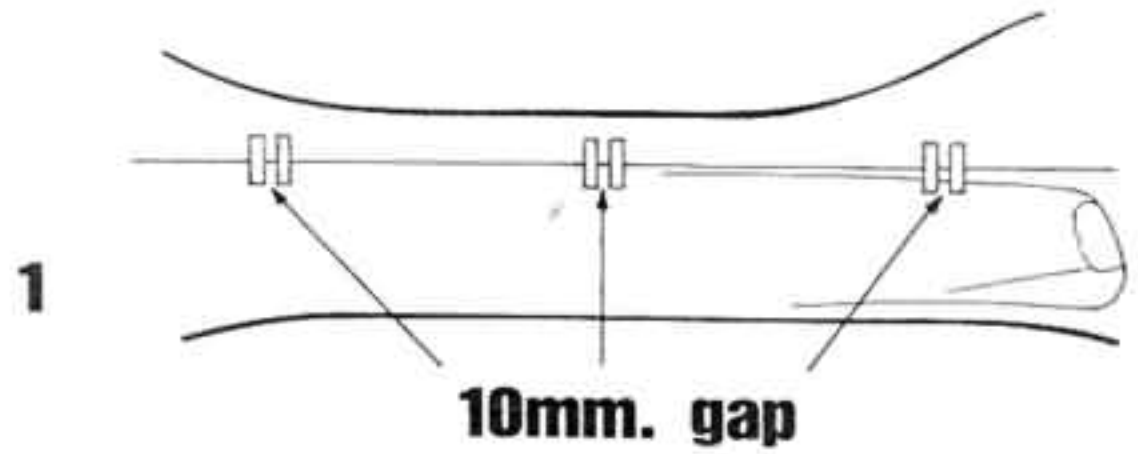

FIG. 23

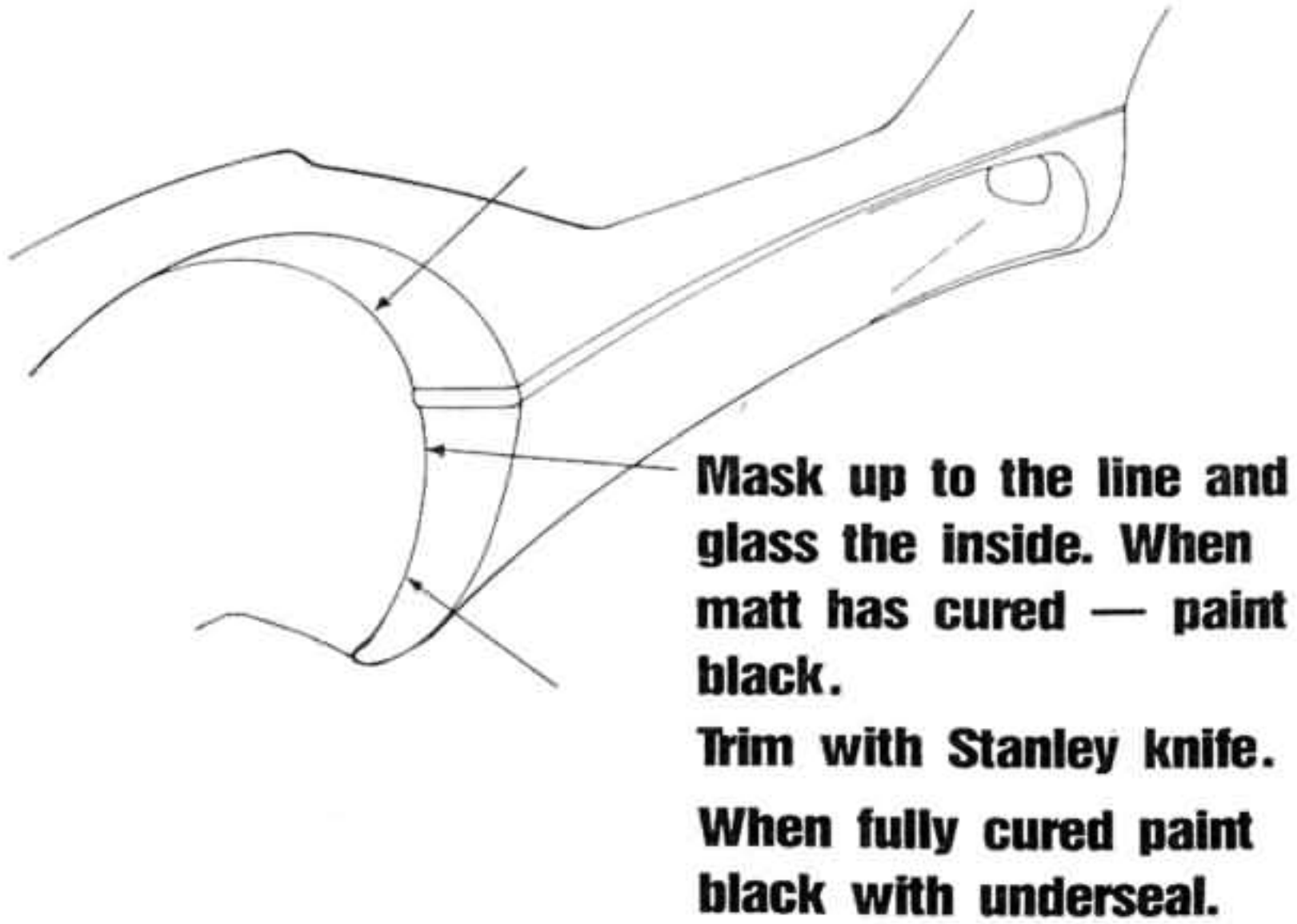
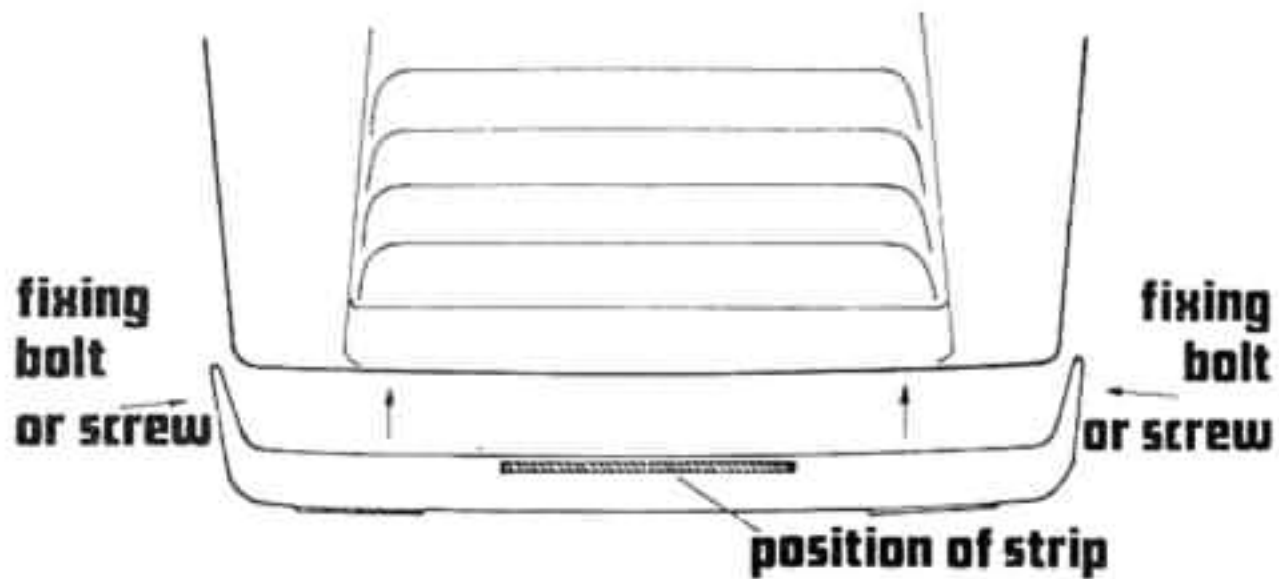

FIG. 24

## FIXING OF REAR BUMPER



### Detail of fixing strip

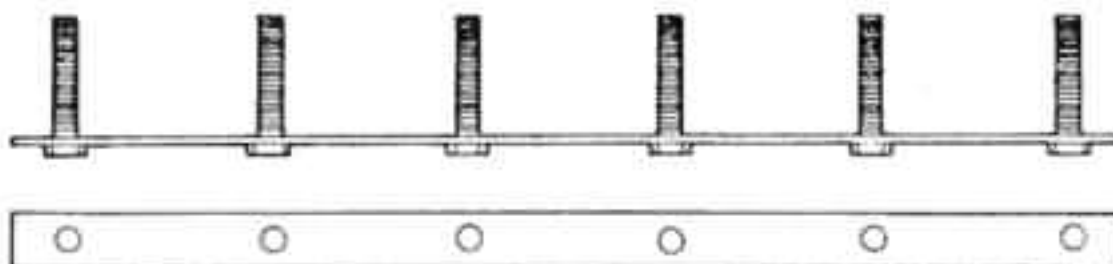
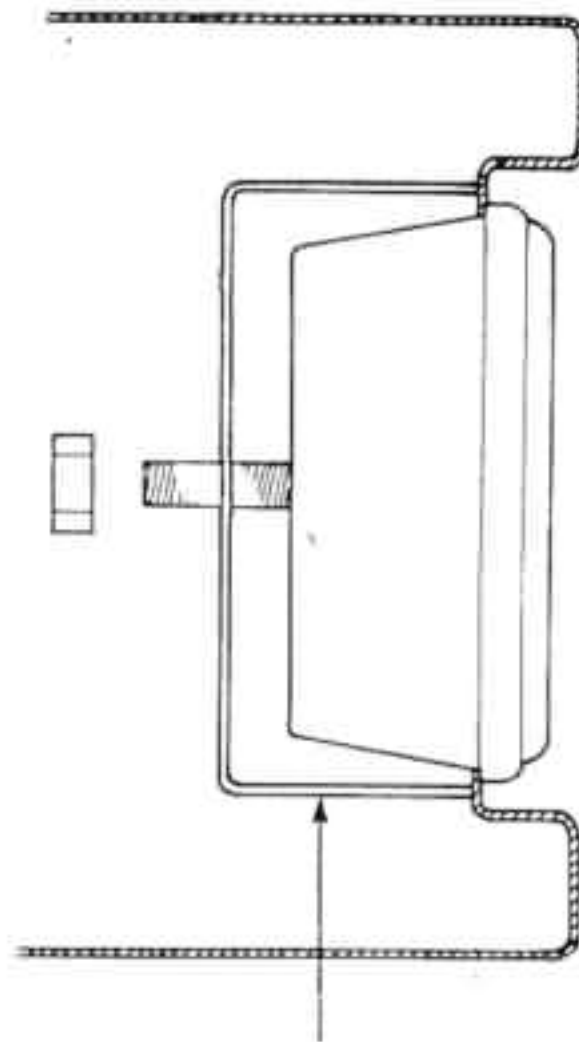
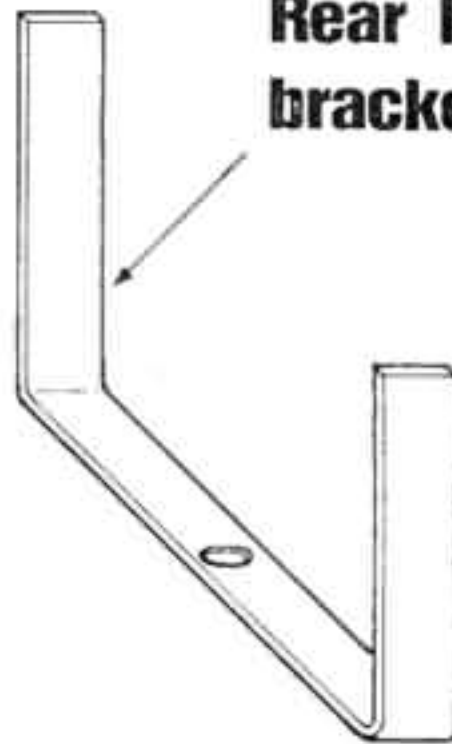

FIG. 25



**Rear lamp retaining  
bracket**



### THE LOUVRE

Is hinged at the top with 2 stainless 2 inch bolt hinges riveted to the shell. The rear end is fixed with special pins (available from NOVA Sports Cars Ltd.). One small tip: fit the pin to the body first and mark the position of the pin on the louvre. An edge trim is available for the louvre.

### THE ROOF SEAL

The roof seal is fitted to the car using only impact adhesive. First make sure the seal is dry and clean and that the part of the roof, where the seal is to be stuck, is also perfectly clean.

Apply the adhesive with a half inch paint brush to the canopy (as per diagram page 26) and the seal. When the adhesive is touch dry, start from the rear of the roof and position the seal on the roof. Run the seal to point 'B', the first outside corner. In order to prevent the seal 'puckering', it should be slit from the outside edge to the edge of the glued section. Run the seal around the corner. This should leave a 'V' shaped gap in the seal. Run the seal to the next corner. This is an inside corner and so calls for a slightly different modification.

Run the seal around the corner and allow it to 'pucker'. Now cut out a 'V' shaped piece. This will allow the seal to flatten out and, if done correctly, the two edges will meet. Run the seal along the roof front edge, dealing with each corner as described. The seal can now be routed to the other end at the back edge. Earlier, we cut a slit in the seal on the outside corners. Using the excess length of seal cut out a 'V' section and glue into position.

FIG. 26

# ROOF SEAL

Cut this from the end

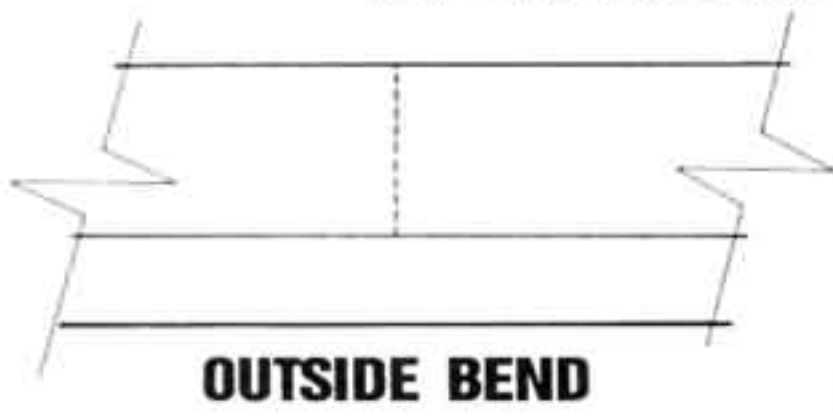

A

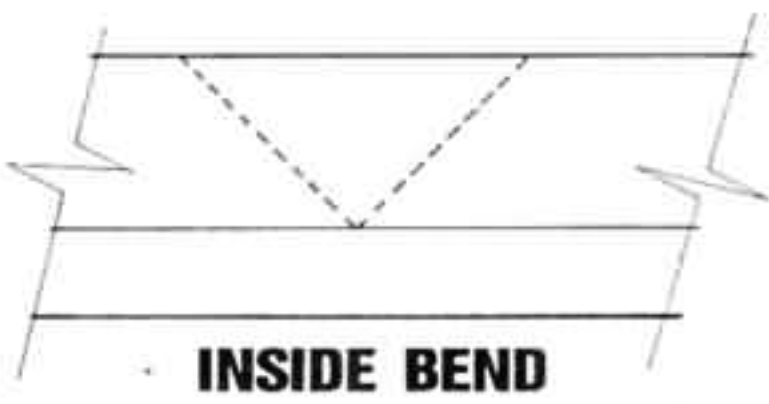
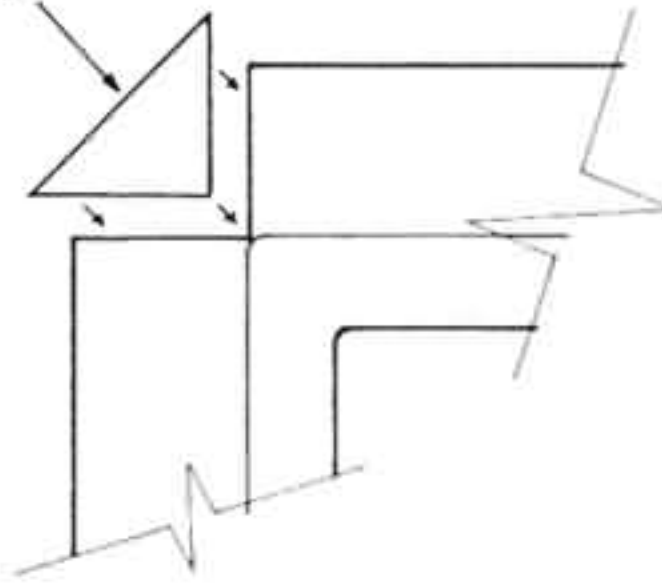

B

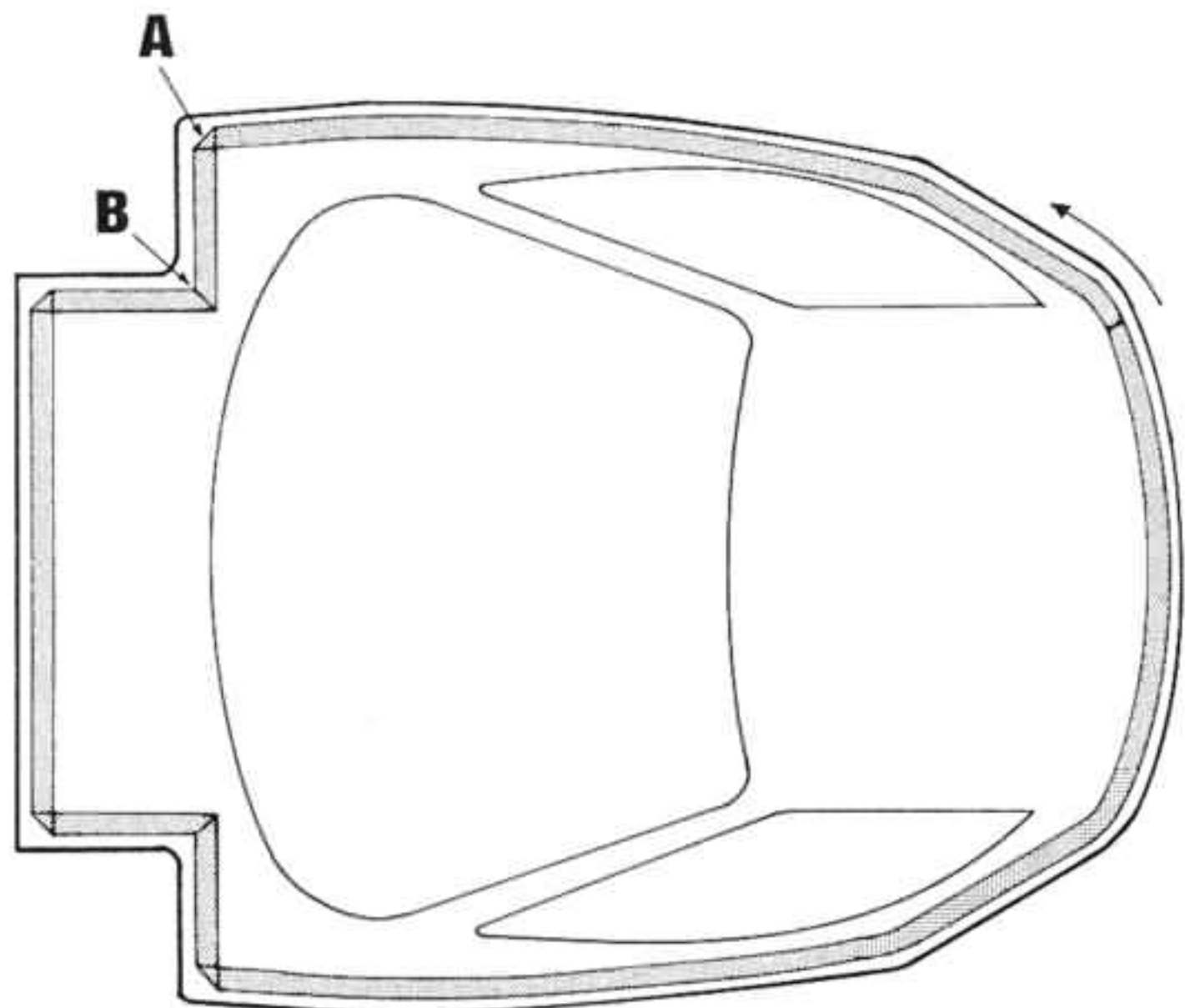
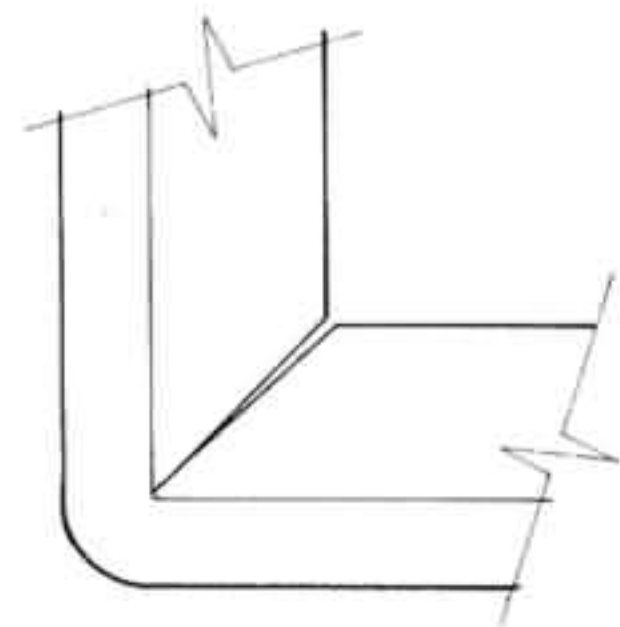

FIG. 27

**VIEW FROM INSIDE CAR**

